

Please check the examination details below before entering your candidate information

Candidate surname

Other names

Pearson Edexcel
International
Advanced Level

Centre Number

Candidate Number

--	--	--	--	--

--	--	--	--

Time 1 hour 45 minutes

Paper
reference

WPH15/01

Physics

International Advanced Level

**UNIT 5: Thermodynamics, Radiation, Oscillations and
Cosmology**

You must have:

Scientific calculator, ruler

Total Marks

Instructions

- Use **black** ink or ball-point pen.
- **Fill in the boxes** at the top of this page with your name, centre number and candidate number.
- Answer **all** questions.
- Answer the questions **in the spaces provided** – *there may be more space than you need.*
- Show all your working in calculations and include units where appropriate.

Information

- The total mark for this paper is 90.
- The marks for **each** question are shown in brackets – *use this as a guide as to how much time to spend on each question.*
- In the question marked with an **asterisk** (*), marks will be awarded for your ability to structure your answer logically, showing how the points that you make are related or follow on from each other where appropriate.
- The list of data, formulae and relationships is printed at the end of this booklet.

Advice

- Read each question carefully before you start to answer it.
- Try to answer every question.
- Check your answers if you have time at the end.
- Good luck with your examination.

Turn over ►

P67821A

©2021 Pearson Education Ltd.

1/1/1/



Pearson

SECTION A

Answer ALL the questions in this section.

For questions 1-10, in Section A, select one answer from A to D and put a cross in the box . If you change your mind, put a line through the box and then mark your new answer with a cross .

- 1 A detector and counter were placed near a radium source. A student measured the count for one minute. He used this value to calculate the count rate in Bq from the source.

Which of the following would increase the accuracy of the student's value for the count rate?

- A Adding the background count rate to the measured count rate.
- B Increasing the counting time to 10 minutes.
- C Repeating the count with a different detector and calculating a mean value.
- D Subtracting the background count from the measured count.

(Total for Question 1 = 1 mark)

- 2 The initial value determined by astronomers for the Hubble constant was smaller than the currently accepted value.

Which of the following statements is correct?

- A The universe is bigger than astronomers initially thought.
- B The universe is not as old as astronomers initially thought.
- C The universe is older than astronomers initially thought.
- D The universe is smaller than astronomers initially thought.

(Total for Question 2 = 1 mark)

- 3 When a train travels across a railway bridge, the bridge may be forced into resonant oscillation.

Which of the following happens **only** when resonance occurs?

- A Damping reduces the amplitude of oscillation.
- B Energy is transferred from the train to the bridge.
- C Resistive forces dissipate energy from the train.
- D The amplitude of oscillation is unusually large.

(Total for Question 3 = 1 mark)



4 In the Sun, nuclear fusion occurs mainly in the core.

Which of the following is a reason for this?

- A Helium nuclei surround the core.
- B Most of the Sun's hydrogen is in the core.
- C The core contains most of the mass of the Sun.
- D The temperature is greatest in the core.

(Total for Question 4 = 1 mark)

5 The gravitational field strength on the surface of Mercury is g_M .
Callisto, a moon of Jupiter, has the same radius as Mercury but only one third of its density.

What is the gravitational field strength on the surface of Callisto?

- A $\frac{g_M}{9}$
- B $\frac{g_M}{3}$
- C $3g_M$
- D $9g_M$

(Total for Question 5 = 1 mark)

6 Tau Ceti is one of the closest stars to the Sun. Tau Ceti has a surface temperature of 5300 K and a luminosity of $0.55 L_{\text{Sun}}$, where L_{Sun} is the luminosity of the Sun.

Which of the following is the correct description of Tau Ceti?

- A main sequence star
- B red dwarf star
- C red giant star
- D white dwarf star

(Total for Question 6 = 1 mark)



- 7 Helium gas in a closed cylinder is heated until the pressure exerted by the helium is four times the original pressure. The volume occupied by the helium stays constant.

The mean square speed of the helium molecules before heating is $\langle v_1^2 \rangle$. The mean square speed of the helium molecules after heating is $\langle v_2^2 \rangle$.

What is the ratio $\frac{\langle v_2^2 \rangle}{\langle v_1^2 \rangle}$?

- A 1
 B 2
 C 4
 D 8

(Total for Question 7 = 1 mark)

- 8 Two stars, P and Q, have approximately the same radius. The surface temperature of star P is twice the surface temperature of star Q.

Star P has a luminosity L_p and star Q has a luminosity L_q .

The ratio $\frac{L_p}{L_q}$ is approximately

- A 2
 B 4
 C 8
 D 16

(Total for Question 8 = 1 mark)



- 9 An object oscillates with simple harmonic motion. The period of oscillation is 0.55 s and the amplitude is 0.25 m.

Which of the following shows a correct calculation of the maximum velocity of the object?

- A $2\pi \times 0.55 \times 0.25$
- B $\frac{2}{0.55} \times 0.25$
- C $(2\pi \times 0.55)^2 \times 0.25$
- D $\left(\frac{2}{0.55}\right)^2 \times 0.25$

(Total for Question 9 = 1 mark)

- 10 Two stars, X and Y, behave as black body radiators. The graphs show how the intensity I of radiation emitted varies with wavelength λ for the two stars.

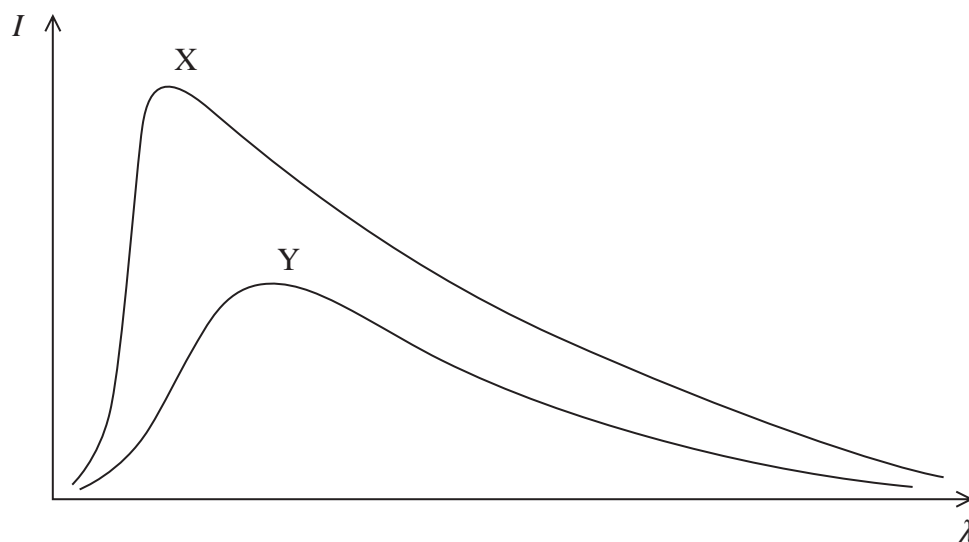

The stars are both viewed from the same distance.

Which of the following statements can be deduced from the two graphs?

- A Star X is brighter and has a higher surface temperature than star Y.
- B Star X is brighter and has a lower surface temperature than star Y.
- C Star X is dimmer and has a higher surface temperature than star Y.
- D Star X is dimmer and has a lower surface temperature than star Y.

(Total for Question 10 = 1 mark)

TOTAL FOR SECTION A = 10 MARKS



SECTION B

Answer ALL questions in the spaces provided.

- 11 The school apparatus shown is used to demonstrate a gas law.

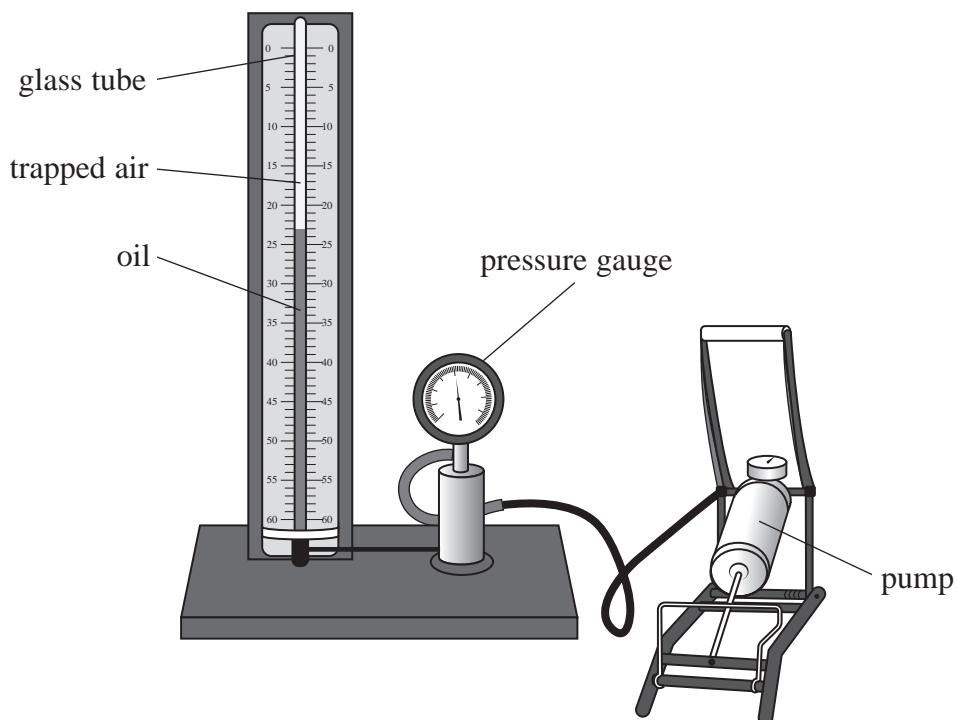

Air is trapped in a glass tube of uniform cross-sectional area. A pump forces oil into the base of the glass tube. This forces the air into a smaller volume. The pressure of the trapped air is displayed on the pressure gauge.

- (a) The pressure of the trapped air increases when the air is forced into a smaller volume.

Explain why, using ideas of molecular motion.

(4)

.....

.....

.....

.....

.....

.....

.....

.....

.....

.....

.....

DO NOT WRITE IN THIS AREA

DO NOT WRITE IN THIS AREA

DO NOT WRITE IN THIS AREA



DO NOT WRITE IN THIS AREA

DO NOT WRITE IN THIS AREA

DO NOT WRITE IN THIS AREA

(b) The apparatus is used in a laboratory where the temperature is 293 K.

When the air occupies a volume of $2.43 \times 10^{-3} \text{ m}^3$ the reading on the pressure gauge is $1.05 \times 10^5 \text{ Pa}$.

Calculate the number of molecules of air trapped in the glass tube.

(2)

.....

.....

.....

.....

Number of molecules of air =

(Total for Question 11 = 6 marks)



P 6 7 8 2 1 A 0 7 3 2



Turn over

12 In recent years, astronomers have discovered sources of fast radio bursts (FRBs) in other galaxies. Studies suggest that these sources may be a type of standard candle.

(a) State what is meant by a standard candle.

(1)

(b) An FRB source emits intense bursts of radio waves, each burst lasting for a fraction of a second. The closest FRB source is in a massive spiral galaxy 4.60×10^{24} m from the Earth.

A detector of area $1.00 \times 10^{-4} \text{ m}^2$ on the surface of the Earth received bursts of radio waves. In one burst, $9.40 \times 10^{-23} \text{ J}$ of energy was received in a time of 1.15 ms.

(i) Show that the luminosity of the source is about $2 \times 10^{35} \text{ W}$.

(4)

(ii) When FRB sources were first discovered, some observers suggested that the bursts might be alien communications.

Suggest why this is unlikely.

luminosity of the Sun = $3.8 \times 10^{26} \text{ W}$

(2)

(Total for Question 12 = 7 marks)



- 13 In the book *Charlie and the Chocolate Factory*, a palace is made entirely from chocolate. Soon after it was made the palace melted, due to energy transfer from the Sun.

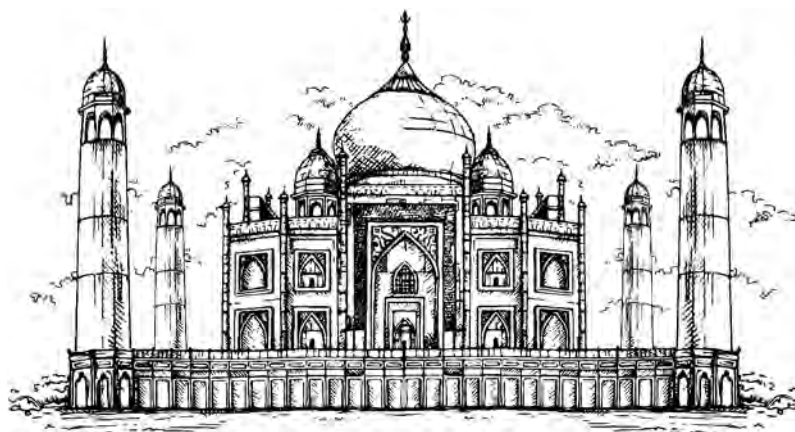

(Source: Morkhatenok/Shutterstock)

The total volume of chocolate used for the palace was 1250 m^3 . The initial temperature of the chocolate palace was 28.5°C . Chocolate melts at a temperature of 36.0°C .

The book states that the palace melted completely in less than a day.

Deduce whether this statement could be correct.

rate of energy transfer to the palace = $7.5 \times 10^5\text{ W}$

density of chocolate = 1325 kg m^{-3}

specific latent heat of chocolate = $4.5 \times 10^4\text{ J kg}^{-1}$

specific heat capacity of chocolate is $1.30 \times 10^3\text{ J kg}^{-1}\text{ K}^{-1}$

(6)

(Total for Question 13 = 6 marks)



P 6 7 8 2 1 A 0 9 3 2

14 A student set up a simple pendulum. The student used a velocity sensor connected to a data logger to record the velocity of the pendulum bob.

(a) The graph shows how the velocity of the bob varied with time.

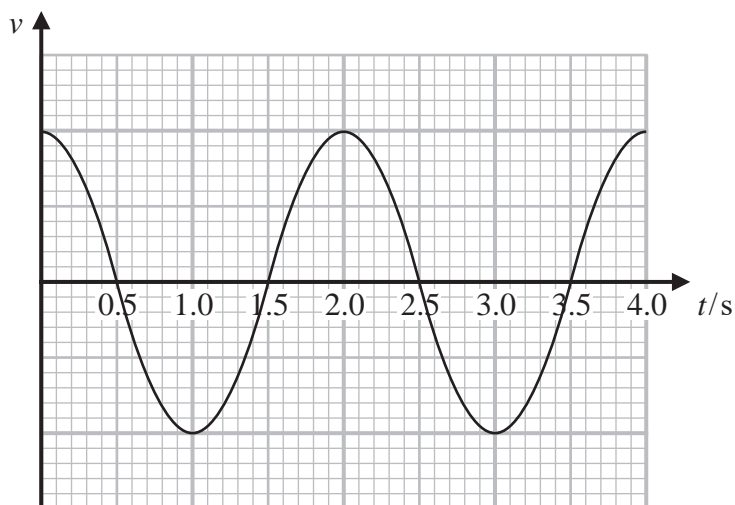

- (i) Add a line to the graph to show how the displacement of the bob varied with time during the same time interval. (2)
- (ii) Determine the length of the simple pendulum. (3)

.....

.....

.....

.....

.....

Length of simple pendulum =

(b) In some experiments, it is an advantage to use a data logger rather than other measuring instruments.

Describe when the use of a data logger is an advantage. (2)

.....

.....

.....

.....

(Total for Question 14 = 7 marks)



DO NOT WRITE IN THIS AREA

DO NOT WRITE IN THIS AREA

DO NOT WRITE IN THIS AREA

BLANK PAGE



P 6 7 8 2 1 A 0 1 1 3 2



Turn over

15 A graph of relative intensity against wavelength for a star is shown.

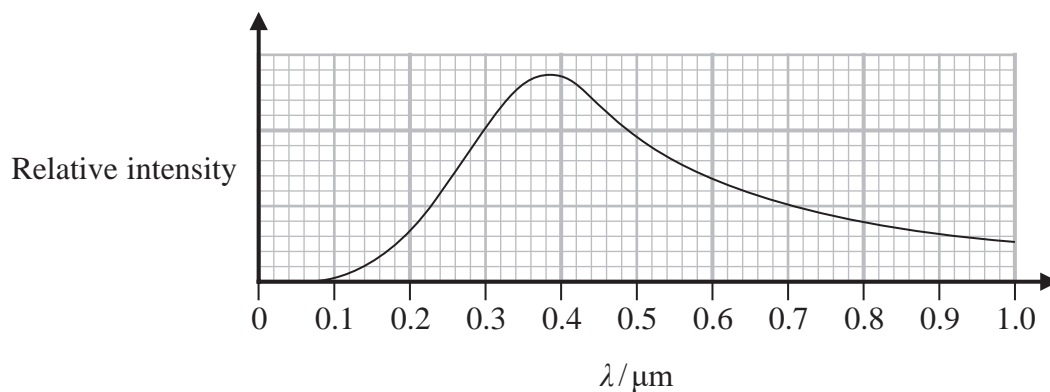

(a) Determine the surface temperature of the star.

(3)

.....

.....

.....

.....

.....

.....

Surface temperature of star =

DO NOT WRITE IN THIS AREA

DO NOT WRITE IN THIS AREA

DO NOT WRITE IN THIS AREA



- (b) Radiation from the star is analysed. The radiation from the star has spectral lines at different wavelengths from the same spectral lines produced by a source in the laboratory, as shown.

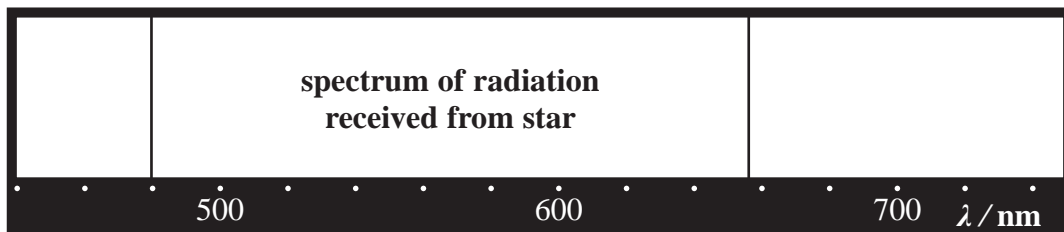

Explain what can be concluded about the star from these results.
Your answer should include a calculation.

(5)

(Total for Question 15 = 8 marks)



16 In 2015, the company SpaceX stated its plan to launch about 4,000 “Starlink” satellites into a low Earth orbit. These satellites would provide a low-cost internet service to people around the world.

By the start of 2020 almost 200 Starlink satellites had been launched into an orbit 550 km above the Earth’s surface.

mass of Earth = 6.0×10^{24} kg

radius of Earth = 6.4×10^6 m

(a) Calculate the orbital time of a Starlink satellite.

(3)

.....

.....

.....

.....

.....

.....

.....

.....

.....

.....

Orbital time of satellite =

(b) Explain why satellites in low Earth orbits have a smaller orbital time than satellites in higher Earth orbits.

(3)

.....

.....

.....

.....

.....

.....

.....

.....



DO NOT WRITE IN THIS AREA

DO NOT WRITE IN THIS AREA

DO NOT WRITE IN THIS AREA

(c) The satellites were launched into orbit using rockets able to make multiple space flights.
Calculate the minimum kinetic energy required to raise the satellite to its lower orbit height.
mass of a Starlink satellite = 227 kg.

(3)

.....

.....

.....

.....

.....

.....

.....

.....

Minimum kinetic energy =

(Total for Question 16 = 9 marks)



Turn over

- 17 A student suspended a spring from a rigid support. She stretched the spring by hanging a mass from the free end of the spring as shown.

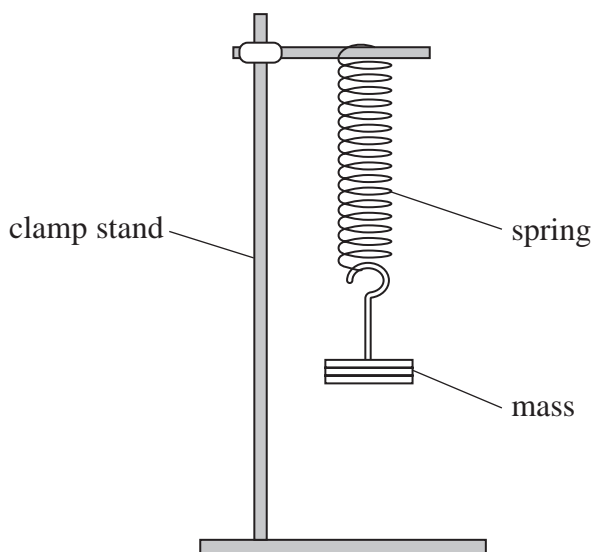

She set the mass into vertical oscillations by displacing it a small distance from its equilibrium position. The spring obeys Hooke's law.

- (a) Explain why the mass moves with simple harmonic motion.

(2)

.....

.....

.....

.....

- (b) When the mass on the end of the spring was 0.200 kg, the extension of the spring was 7.50 cm when the mass was in equilibrium.

- (i) Show that the stiffness k of the spring is about 26 N m^{-1} .

(2)

.....

.....

.....

.....

DO NOT WRITE IN THIS AREA

DO NOT WRITE IN THIS AREA

DO NOT WRITE IN THIS AREA



- (ii) The student used a stopwatch to determine the frequency of oscillation f of the mass m . She repeated this procedure for four more values of m and obtained the following graph.

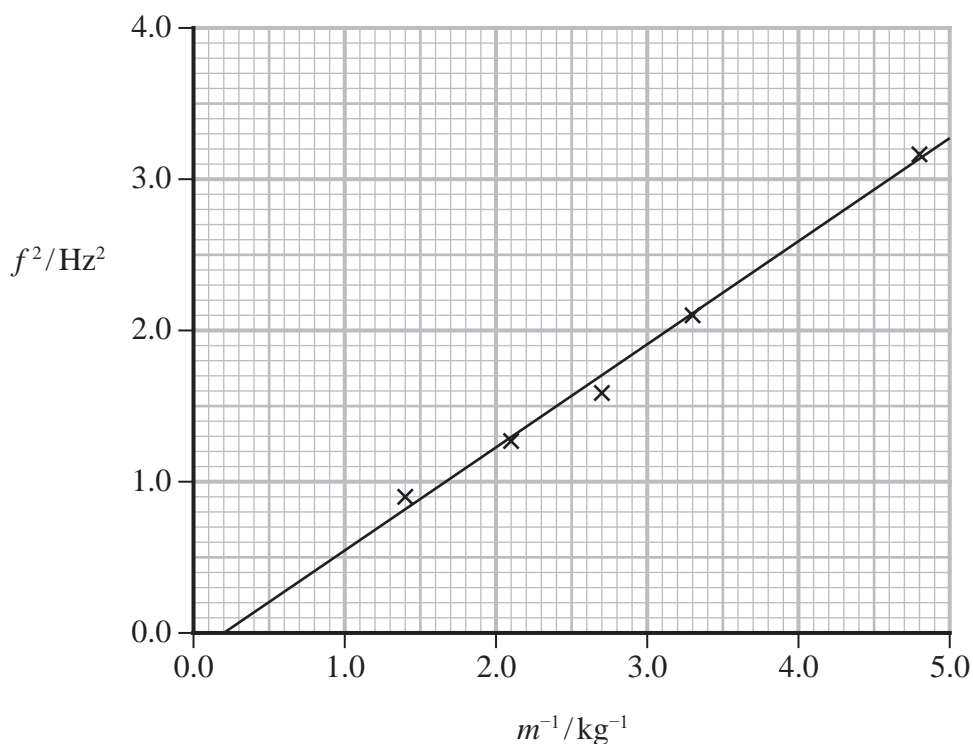

The student used the graph to determine a value for k .

Deduce whether the graph gives a value of k consistent with the value in (i).

(6)

.....

.....

.....

.....

.....

.....

.....

.....

.....

.....

.....

.....

.....

.....

.....

.....

.....

.....

.....

.....

.....

.....

.....

(Total for Question 17 = 10 marks)



Turn over



P 6 7 8 2 1 A 0 1 7 3 2

18 Many countries use nuclear power stations to provide electrical power. Energy is released when nuclei undergo fission in the core of the reactor.

(a) State what is meant by nuclear fission.

(1)

(b) (i) Sketch a graph to show how the binding energy per nucleon varies with nucleon number, for a wide range of isotopes.

(2)

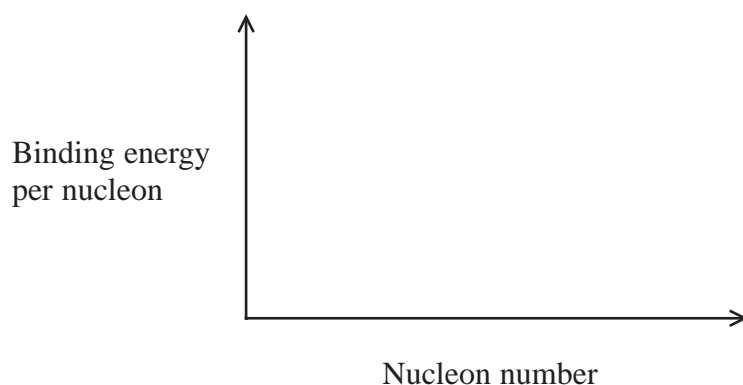

(ii) Mark the position of iron-56 on your graph.

(1)

(c) Complete the nuclear equation below.

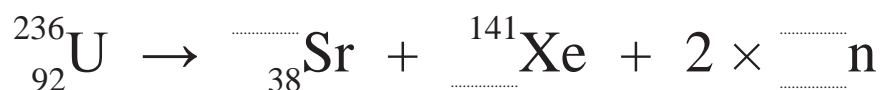

(2)

(d) Calculate, in MeV, the binding energy per nucleon for a nucleus of ${}_{92}^{236}\text{U}$.

	Mass / GeV/c ²
${}_{92}^{236}\text{U}$	219.8750
n	0.93956
p	0.93827

(2)

Binding energy per nucleon = MeV



DO NOT WRITE IN THIS AREA

DO NOT WRITE IN THIS AREA

DO NOT WRITE IN THIS AREA

***(e)** Ultraviolet radiation (UV) is produced when alpha particles interact with air.
This can be used to detect alpha particles when a nuclear reactor is decommissioned.

Explain how UV is produced by alpha particles in the air, and why detecting UV has advantages compared with detecting alpha particles directly.

(6)

.....

.....

.....

.....

.....

.....

.....

.....

.....

.....

.....

.....

.....

.....

.....

.....

.....

.....

.....

.....

.....

(Total for Question 18 = 14 marks)



Turn over



19 A pacemaker is a device used to regulate a person's heart rate.

Some of the first electronic pacemakers used an isotope of plutonium, Pu-238, as the power source.

(a) Pu-238 decays by alpha emission.

Show that the energy released when a nucleus of Pu-238 decays into a nucleus of uranium is about 5.6 MeV.

	Mass/u
Plutonium nucleus	237.999089
Uranium nucleus	233.991578
α -particle	4.001506

(5)

.....

.....

.....

.....

.....

.....

.....

.....

.....

.....

.....

.....

.....

.....

.....

.....

.....

.....

.....

.....

.....



DO NOT WRITE IN THIS AREA

DO NOT WRITE IN THIS AREA

DO NOT WRITE IN THIS AREA

(b) In one pacemaker, the activity of the plutonium source was measured to be 6.75×10^{10} Bq in 2020.

Calculate the power of the source, in W, when it was fitted 40 years ago.

half-life of Pu-238 = 87.7 years

energy of α -particle = 5.6 MeV

(5)

.....

.....

.....

.....

.....

.....

.....

.....

.....

.....

.....

.....

.....

.....

.....

.....

.....

.....

.....

.....

.....

.....

Power of source = W



(c) Another source that was used in early pacemakers was promethium-147. This emits β -particles. The energy spectrum for the β -particles is shown.

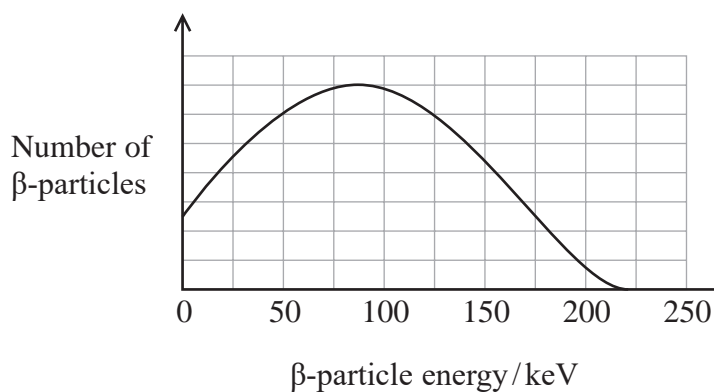

The graphs below show how the range of beta particles depends on the beta particle energy, for different materials.

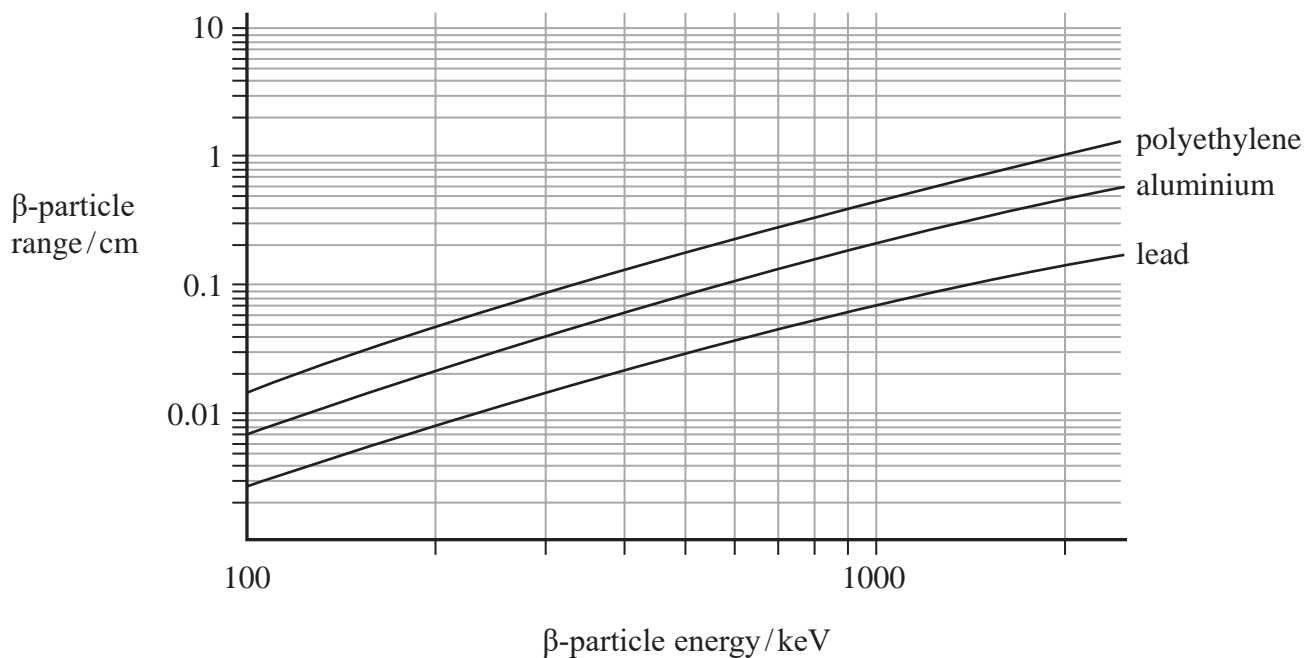

It is suggested that a layer of polyethylene, of thickness 0.5 cm, would be able to absorb all the beta particles emitted from a promethium-147 source.

Comment on this suggestion.

(3)

.....

.....

.....

.....

.....

.....

.....

.....

.....

.....

(Total for Question 19 = 13 marks)

TOTAL FOR SECTION B = 80 MARKS

TOTAL FOR PAPER = 90 MARKS

DO NOT WRITE IN THIS AREA

DO NOT WRITE IN THIS AREA

DO NOT WRITE IN THIS AREA



List of data, formulae and relationships

Acceleration of free fall	$g = 9.81 \text{ m s}^{-2}$	(close to Earth's surface)
Boltzmann constant	$k = 1.38 \times 10^{-23} \text{ J K}^{-1}$	
Coulomb's law constant	$k = 1/4\pi\epsilon_0$ $= 8.99 \times 10^9 \text{ N m}^2 \text{ C}^{-2}$	
Electron charge	$e = -1.60 \times 10^{-19} \text{ C}$	
Electron mass	$m_e = 9.11 \times 10^{-31} \text{ kg}$	
Electronvolt	$1 \text{ eV} = 1.60 \times 10^{-19} \text{ J}$	
Gravitational constant	$G = 6.67 \times 10^{-11} \text{ N m}^2 \text{ kg}^{-2}$	
Gravitational field strength	$g = 9.81 \text{ N kg}^{-1}$	(close to Earth's surface)
Permittivity of free space	$\epsilon_0 = 8.85 \times 10^{-12} \text{ F m}^{-1}$	
Planck constant	$h = 6.63 \times 10^{-34} \text{ J s}$	
Proton mass	$m_p = 1.67 \times 10^{-27} \text{ kg}$	
Speed of light in a vacuum	$c = 3.00 \times 10^8 \text{ m s}^{-1}$	
Stefan-Boltzmann constant	$\sigma = 5.67 \times 10^{-8} \text{ W m}^{-2} \text{ K}^{-4}$	
Unified atomic mass unit	$u = 1.66 \times 10^{-27} \text{ kg}$	

Unit 1

Mechanics

Kinematic equations of motion

$$s = \frac{(u + v)t}{2}$$

$$v = u + at$$

$$s = ut + \frac{1}{2}at^2$$

$$v^2 = u^2 + 2as$$

Forces

$$\Sigma F = ma$$

$$g = \frac{F}{m}$$

$$W = mg$$

Momentum

$$p = mv$$

Moment of force

$$\text{moment} = Fx$$

Work and energy

$$\Delta W = F\Delta s$$

$$E_k = \frac{1}{2}mv^2$$

$$\Delta E_{\text{grav}} = mg\Delta h$$

Power

$$P = \frac{E}{t}$$

$$P = \frac{W}{t}$$

DO NOT WRITE IN THIS AREA

DO NOT WRITE IN THIS AREA

DO NOT WRITE IN THIS AREA



Efficiency

$$\text{efficiency} = \frac{\text{useful energy output}}{\text{total energy input}}$$

$$\text{efficiency} = \frac{\text{useful power output}}{\text{total power input}}$$

Materials

Density

$$\rho = \frac{m}{V}$$

Stokes' law

$$F = 6\pi\eta rv$$

Hooke's law

$$\Delta F = k\Delta x$$

Elastic strain energy

$$\Delta E_{\text{el}} = \frac{1}{2} F\Delta x$$

Young modulus

$$E = \frac{\sigma}{\varepsilon} \text{ where}$$

$$\text{Stress } \sigma = \frac{F}{A}$$

$$\text{Strain } \varepsilon = \frac{\Delta x}{x}$$

DO NOT WRITE IN THIS AREA

DO NOT WRITE IN THIS AREA

DO NOT WRITE IN THIS AREA



Unit 2**Waves**

Wave speed	$v = f\lambda$
Speed of a transverse wave on a string	$v = \sqrt{\frac{T}{\mu}}$
Intensity of radiation	$I = \frac{P}{A}$
Refractive index	$n_1 \sin \theta_1 = n_2 \sin \theta_2$ $n = \frac{c}{v}$
Critical angle	$\sin C = \frac{1}{n}$
Diffraction grating	$n\lambda = d \sin \theta$

Electricity

Potential difference	$V = \frac{W}{Q}$
Resistance	$R = \frac{V}{I}$
Electrical power, energy	$P = VI$ $P = I^2R$ $P = \frac{V^2}{R}$ $W = VIt$
Resistivity	$R = \frac{\rho l}{A}$
Current	$I = \frac{\Delta Q}{\Delta t}$ $I = nqvA$
Resistors in series	$R = R_1 + R_2 + R_3$
Resistors in parallel	$\frac{1}{R} = \frac{1}{R_1} + \frac{1}{R_2} + \frac{1}{R_3}$

Particle nature of light

Photon model	$E = hf$
Einstein's photoelectric equation	$hf = \phi + \frac{1}{2}mv_{\max}^2$
de Broglie wavelength	$\lambda = \frac{h}{p}$



Unit 4

Mechanics

Impulse

$$F\Delta t = \Delta p$$

Kinetic energy of a non-relativistic particle

$$E_k = \frac{p^2}{2m}$$

motion in a circle

$$v = \omega r$$

$$T = \frac{2\pi}{\omega}$$

$$a = \frac{v^2}{r}$$

Centripetal force

$$F = ma = \frac{mv^2}{r}$$

$$F = m\omega^2 r$$

Electric and magnetic fields

Electric field

$$E = \frac{F}{Q}$$

Coulomb's law

$$F = \frac{Q_1 Q_2}{4\pi\epsilon_0 r^2}$$

$$E = \frac{Q}{4\pi\epsilon_0 r^2}$$

$$E = \frac{V}{d}$$

Electrical Potential

$$V = \frac{Q}{4\pi\epsilon_0 r}$$

Capacitance

$$C = \frac{Q}{V}$$

Energy stored in capacitor

$$W = \frac{1}{2} QV$$

$$W = \frac{1}{2} CV^2$$

$$W = \frac{1}{2} \frac{Q^2}{C}$$

Capacitor discharge

$$Q = Q_0 e^{-t/RC}$$



Resistor capacitor discharge

$$I = I_0 e^{-t/RC}$$

$$V = V_0 e^{-t/RC}$$

$$\ln Q = \ln Q_0 - \frac{t}{RC}$$

$$\ln I = \ln I_0 - \frac{t}{RC}$$

$$\ln V = \ln V_0 - \frac{t}{RC}$$

In a magnetic field

$$F = Bqv \sin \theta$$

$$F = BIl \sin \theta$$

Faraday's and Lenz's laws

$$\mathcal{E} = \frac{-d(N\phi)}{dt}$$

Nuclear and particle physics

In a magnetic field

$$r = \frac{p}{BQ}$$

Mass-energy

$$\Delta E = c^2 \Delta m$$

DO NOT WRITE IN THIS AREA

DO NOT WRITE IN THIS AREA

DO NOT WRITE IN THIS AREA



Unit 5

Thermodynamics

Heating	$\Delta E = mc\Delta\theta$ $\Delta E = L\Delta m$
Ideal gas equation	$pV = NkT$
Molecular kinetic theory	$\frac{1}{2}m\langle c^2 \rangle = \frac{3}{2}kT$

Nuclear decay

Mass-energy	$\Delta E = c^2\Delta m$
Radio-active decay	$A = -\lambda N$ $\frac{dN}{dt} = -\lambda N$ $\lambda = \frac{\ln 2}{t_{1/2}}$ $N = N_0 e^{-\lambda t}$ $A = A_0 e^{-\lambda t}$

Oscillations

Simple harmonic motion	$F = kx$ $a = -\omega^2 x$ $x = A \cos \omega t$ $v = -A\omega \sin \omega t$ $a = A\omega^2 \cos \omega t$
------------------------	---

Simple harmonic oscillator

$$T = \frac{1}{f} = \frac{2\pi}{\omega}$$
$$\omega = 2\pi f$$
$$T = 2\pi\sqrt{\frac{m}{k}}$$
$$T = 2\sqrt{\frac{l}{g}}$$



Astrophysics and Cosmology

Gravitational field strength $g = F/m$

Gravitational force $F = \frac{Gm_1m_2}{r^2}$

Gravitational field $g = \frac{Gm}{r^2}$

Gravitational potential $V_{grav} = \frac{-Gm}{r}$

Stephan-Boltzman law $L = \sigma T^4 A$

Wein's law $\lambda_{max} T = 2.898 \times 10^{-3} \text{ m K}$

Intensity of radiation $I = \frac{L}{4 d^2}$

Redshift of electromagnetic radiation $z = \frac{\Delta\lambda}{\lambda} \approx \frac{\Delta f}{f} \approx \frac{v}{c}$

Cosmological expansion $v = H_0 d$

DO NOT WRITE IN THIS AREA

DO NOT WRITE IN THIS AREA

DO NOT WRITE IN THIS AREA



DO NOT WRITE IN THIS AREA

DO NOT WRITE IN THIS AREA

DO NOT WRITE IN THIS AREA

BLANK PAGE



P 6 7 8 2 1 A 0 3 1 3 2

DO NOT WRITE IN THIS AREA

DO NOT WRITE IN THIS AREA

DO NOT WRITE IN THIS AREA

BLANK PAGE

