

Please check the examination details below before entering your candidate information

Candidate surname

Other names

Pearson Edexcel
International
Advanced Level

Centre Number

--	--	--	--	--

Candidate Number

--	--	--	--	--

Tuesday 7 January 2020

Afternoon (Time: 1 hour 45 minutes)

Paper Reference **WPH14/01**

Physics

International Advanced Level

Unit 4: Further Mechanics, Fields and Particles

You must have:

Scientific calculator, Ruler

Total Marks

--

Instructions

- Use **black** ink or **black** ball-point pen.
- **Fill in the boxes** at the top of this page with your name, centre number and candidate number.
- Answer **all** questions.
- Answer the questions in the spaces provided – *there may be more space than you need.*
- **Show all your working out** in calculations and include units where appropriate.

Information

- The total mark for this paper is 90.
- The marks for **each** question are shown in brackets – *use this as a guide as to how much time to spend on each question.*
- In the question marked with an **asterisk** (*), marks will be awarded for your ability to structure your answer logically showing how the points that you make are related or follow on from each other where appropriate.
- The list of data, formulae and relationships is printed at the end of this booklet.

Advice

- Read each question carefully before you start to answer it.
- Try to answer every question.
- Check your answers if you have time at the end.

Turn over ►

P60493A

©2020 Pearson Education Ltd.

1/1/1/1/1/



Pearson

SECTION A

Answer ALL questions.

For questions 1–10 select one answer from A to D and put a cross in the box ☒.
If you change your mind, put a line through the box ☒ and then
mark your new answer with a cross ☒.

- 1 A neutron can decay to produce a proton.

Which of the following equations correctly shows neutron decay?

- A $n \rightarrow p + e^+ + \bar{\nu}_e$
- B $n \rightarrow p + e^+ + \nu_e$
- C $n \rightarrow p + e^- + \bar{\nu}_e$
- D $n \rightarrow p + e^- + \nu_e$

(Total for Question 1 = 1 mark)

- 2 At distance d from a point charge of magnitude q the potential is V .

Which of the following is the potential at a distance $4d$ from a point charge of magnitude $2q$?

- A $\frac{V}{4}$
- B $\frac{V}{2}$
- C V
- D $2V$

(Total for Question 2 = 1 mark)

- 3 A ball of mass m travelling with velocity v strikes a wall at right angles. It bounces off the wall in the opposite direction at the same speed.

Which of the following is the impulse on the wall?

- A mv
- B $2mv$
- C $-mv$
- D $-2mv$

(Total for Question 3 = 1 mark)

DO NOT WRITE IN THIS AREA

DO NOT WRITE IN THIS AREA

DO NOT WRITE IN THIS AREA



4 The diagram shows equipotential lines about a point charge.

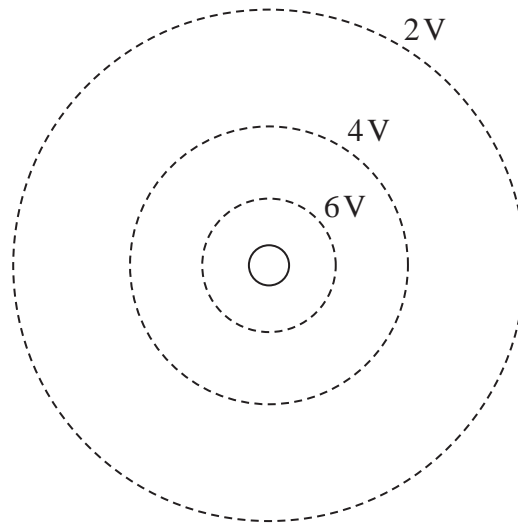

Which of the following diagrams shows a possible combination of electric field lines and polarity of point charge to produce this pattern?

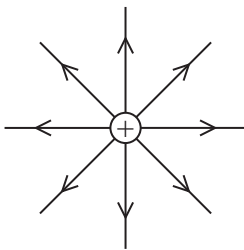

A

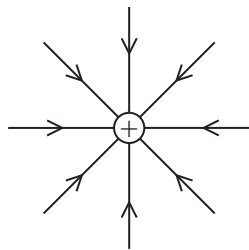

B

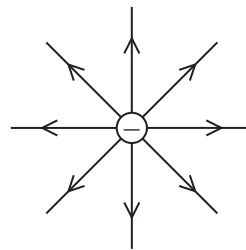

C

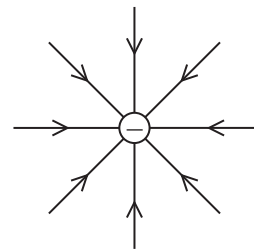

D

(Total for Question 4 = 1 mark)



- 5 The diagram shows a potential difference applied across two conducting parallel plates.

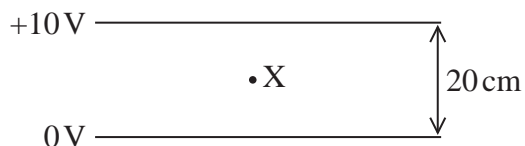

Point X is midway between the plates.

Which of the following is the electric field strength at point X?

- A 50 V m^{-1} upwards
- B 50 V m^{-1} downwards
- C 100 V m^{-1} upwards
- D 100 V m^{-1} downwards

(Total for Question 5 = 1 mark)

- 6 A gamma photon of energy 18 MeV produces a particle and its antiparticle.

Which of the following will give the maximum possible mass of the particle in kg?

- A $\frac{9 \times 1.6 \times 10^{-19}}{3 \times 10^8}$
- B $\frac{9 \times 10^6 \times 1.6 \times 10^{-19}}{3 \times 10^8}$
- C $\frac{9 \times 1.6 \times 10^{-19}}{(3 \times 10^8)^2}$
- D $\frac{9 \times 10^6 \times 1.6 \times 10^{-19}}{(3 \times 10^8)^2}$

(Total for Question 6 = 1 mark)



- 7 A current-carrying wire is placed between two magnetic poles as shown. The magnetic flux density in the region between the poles is 0.070 T .

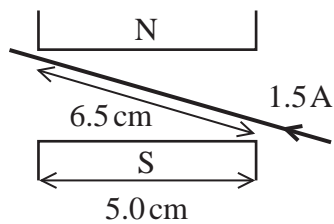

Which of the following gives the magnitude of the force on the wire, in newton, and its direction?

- A $0.070 \times 1.5 \times 0.050$ into page
- B $0.070 \times 1.5 \times 0.065$ into page
- C $0.070 \times 1.5 \times 0.050$ out of page
- D $0.070 \times 1.5 \times 0.065$ out of page

(Total for Question 7 = 1 mark)

- 8 Point charges of $+q$ and $-q$ are placed at X and Y respectively.

When another charge is placed at Z, the resultant force on the charge at X is zero.

Distance XY equals distance YZ.

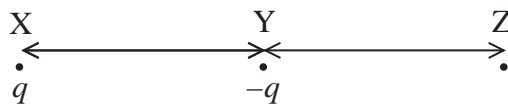

Which of the following is the charge placed at Z?

- A $\frac{q}{4}$
- B $\frac{q}{2}$
- C $2q$
- D $4q$

(Total for Question 8 = 1 mark)



9 The diagram shows the momenta P and Q of two bodies about to collide.

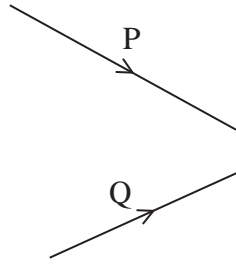

When the bodies collide they merge and move on as a single body.

Which of the following diagrams shows the resultant momentum?

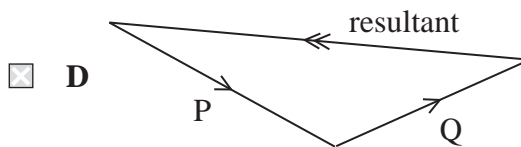
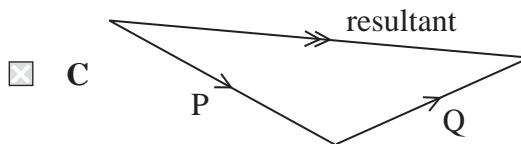
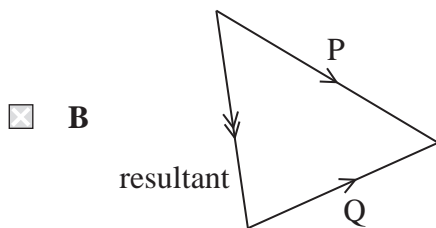
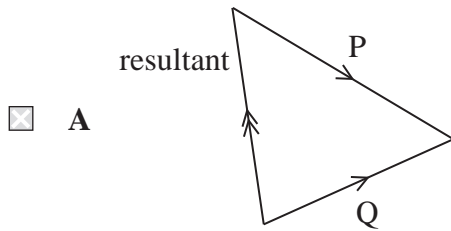

(Total for Question 9 = 1 mark)



10 In an electron deflection tube, electrons are released by passing a current through a metal filament.

What is the name of the process that releases the electrons?

- A electron diffraction
- B ionisation
- C photoelectric effect
- D thermionic emission

(Total for Question 10 = 1 mark)

TOTAL FOR SECTION A = 10 MARKS



SECTION B

Answer ALL questions. Write your answers in the spaces provided.

11 A section from the periodic table is shown.

Element symbol	Zr	Nb	Mo	Tc	Ru	Rh	Pd
Atomic number	40	41	42	43	44	45	46

Technetium (Tc) is produced when a deuterium ion collides with a nucleus of one of the other elements shown in the table. In this process a number of neutrons are also released.

Deuterium is an isotope of hydrogen with 1 proton and 1 neutron.

Complete the nuclear equation to determine the element and the number of neutrons released.



(Total for Question 11 = 3 marks)

DO NOT WRITE IN THIS AREA

DO NOT WRITE IN THIS AREA

DO NOT WRITE IN THIS AREA



DO NOT WRITE IN THIS AREA

DO NOT WRITE IN THIS AREA

DO NOT WRITE IN THIS AREA

12 The following passage is taken from an article about the history of particle physics.

Mystery Particle

By 1932 scientists knew of the existence of the subatomic particles the electron, the proton and the neutron. These were believed to be the fundamental particles.

In 1936 scientists were using tracks of cosmic rays to identify a predicted particle known as a meson. Instead, another particle was discovered, the muon. This was so surprising that Nobel Prize winning physicist Isidor Rabi said “Who ordered that?”

Describe how the underlined particles fit into the standard model.

.....

.....

.....

.....

.....

.....

.....

.....

.....

.....

.....

.....

.....

.....

.....

.....

.....

(Total for Question 12 = 6 marks)



Turn over

13 The photograph shows a jumping toy.



The head is pushed down onto the base, compressing a spring. When released the spring expands and the toy jumps into the air.

A student investigated the toy.

The student placed the toy on a balance to measure the force required to compress the spring. The force was 14 N when the spring was fully compressed by 1.7 cm.

When the toy was launched it jumped to a height of 1.5 m.

(a) Show that the maximum energy stored in the compressed spring was about 0.1 J.

(2)

.....

.....

.....

(b) Initially the spring was fully compressed. As the toy was released, the head accelerated upwards on its own until the spring was uncompressed. The head then pulled the base upwards and they moved together at the same speed.

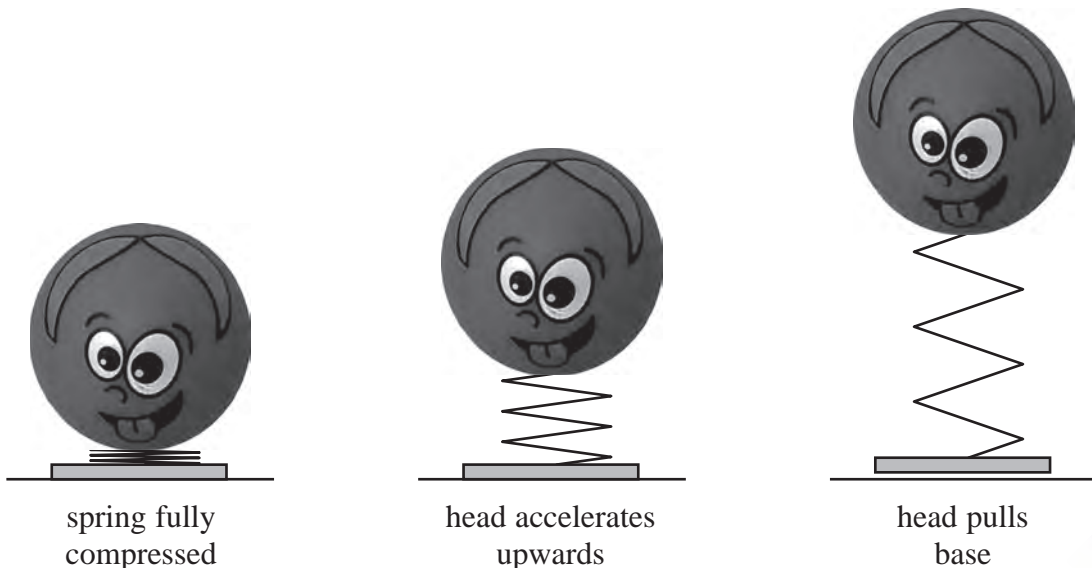

DO NOT WRITE IN THIS AREA

DO NOT WRITE IN THIS AREA

DO NOT WRITE IN THIS AREA

The student used the elastic potential energy stored in the spring to determine the maximum speed of the head.

The student used the gravitational potential energy gained by the whole toy to determine its initial upwards speed.

Determine whether the toy obeys the law of conservation of momentum using values of speed calculated in this way.

mass of head = 6.4 g

mass of whole toy = 7.2 g

maximum height of jump = 1.5 m

(5)

.....

.....

.....

.....

.....

.....

.....

.....

.....

.....

(c) Determine whether kinetic energy was conserved as the head began to pull the base upwards.

(2)

.....

.....

.....

.....

(Total for Question 13 = 9 marks)

DO NOT WRITE IN THIS AREA

DO NOT WRITE IN THIS AREA

DO NOT WRITE IN THIS AREA



P 6 0 4 9 3 A 0 1 1 2 8



Turn over

14 A track for go-karts is being built in a park.

The design criteria state that the track must have semicircular ends with straight track in between, as shown.

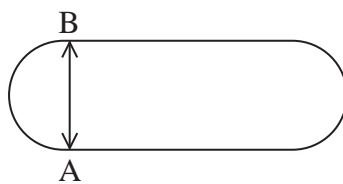

The track must allow the go-kart to travel safely at speeds up to 35.0 km per hour (9.72 m s^{-1}) on the bends.

mass of go-kart and driver = 185 kg

diameter AB of semicircular end = 30.0 m

(a) For one design the track is horizontal.

As the go-kart goes round the semicircular end of the track, centripetal force is provided by friction between the track and the tyres. This is shown in the free body force diagram below.

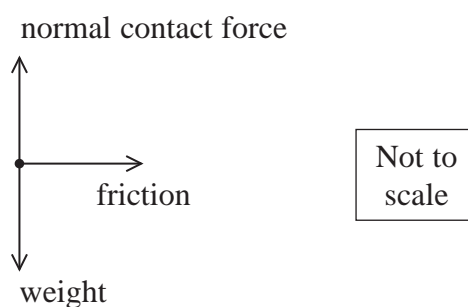

Show that this design meets the design criteria.

maximum frictional force = 1180 N

(2)

.....

.....

.....

.....

.....

.....



- (b) A second design uses a track that is banked at the semicircular ends. The track is banked at an angle θ to the horizontal.

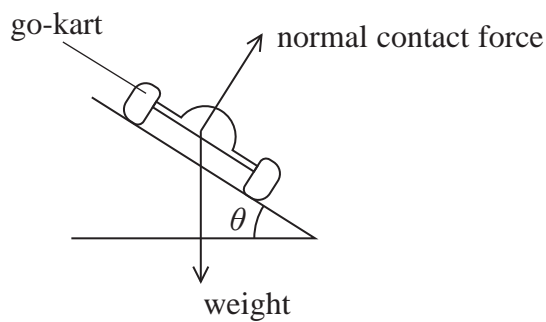

At a particular speed v , the go-kart can follow the track without any frictional force perpendicular to its motion. The diagram shows the forces on the go-kart as it is moving away.

(i) Show that $\tan \theta = \frac{2v^2}{gd}$

where d is the diameter AB of the curved part of the track.

(3)

- (ii) Calculate the angle θ using the stated design criteria for this track.

(2)

Angle =



(c) A banked track will cost more to build.

Suggest whether there are any significant advantages that would justify the cost.

(2)

.....

.....

.....

.....

(Total for Question 14 = 9 marks)

DO NOT WRITE IN THIS AREA

DO NOT WRITE IN THIS AREA

DO NOT WRITE IN THIS AREA



15 In 1908 Rutherford, Geiger and Marsden investigated the interaction of alpha particles with matter. In one set of experiments they directed alpha particles towards a thin gold foil.

(a) State why the alpha source and gold foil were contained in a vacuum.

(1)

*(b) At that time, one model for the structure of atoms was the plum pudding model proposed by J J Thompson. In this model, the positive charge and mass were spread evenly throughout the atom. Negatively charged electrons were distributed within the atom.

Discuss the extent to which the results of the alpha particle scattering experiments justified replacing the plum pudding model with a nuclear model of the atom.

(6)

(Total for Question 15 = 7 marks)



- 16 Some spiders may be seen suddenly moving up into the air, even when there is no wind. This happens when they let out strands of web.

The spiders are pulled upwards as the electrically charged strands of web interact with the Earth's electric field.

The average strength of the Earth's electric field is 120 V m^{-1} downwards.

- (a) State, with a reason, the polarity of the charge on the strands of web.

(1)

- (b) A spider moves upwards after letting out a strand of web.

Determine the initial upwards acceleration of the spider.

mass of spider = $3.00 \times 10^{-6} \text{ kg}$

total magnitude of charge on a strand of web = $3.00 \times 10^{-7} \text{ C}$

(5)

Acceleration =



DO NOT WRITE IN THIS AREA

DO NOT WRITE IN THIS AREA

DO NOT WRITE IN THIS AREA

(c) The Earth has an electric field because charge is distributed over its surface.

Determine the quantity of charge on 1 m^2 of the Earth's surface which would cause an electric field of 120 V m^{-1} .

You should assume that the charge is distributed evenly.

radius of Earth = 6400 km

(3)

Charge =

(Total for Question 16 = 9 marks)



Turn over



P 6 0 4 9 3 A 0 1 7 2 8

- 17 A student is designing a night light for a child. When switched on, the night light should come on brightly and its intensity should then gradually decrease to zero.

The time taken for the light intensity to decrease to zero should be as close to 10 minutes as possible. The time must not be less than 10 minutes.

- (a) The diagram shows the student's design.

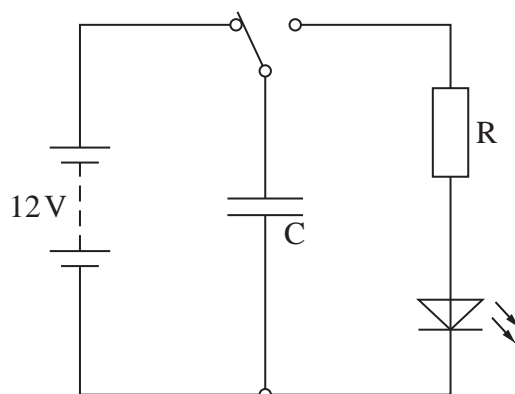

The student uses a light emitting diode (LED) and a resistor R . The LED stops emitting light when the potential difference across it falls to 1.4 V. The student assumes the LED has a constant resistance of $340\ \Omega$.

Capacitors with the following capacitances are available: 0.50 F, 0.51 F, 0.54 F, 0.58 F, 0.60 F.

Determine which capacitance the student should use.

resistance of $R = 860\ \Omega$

(4)



- (b) In practice, the resistance of the LED does not stay constant. The graph shows how current varies with potential difference (p.d.) for the LED.

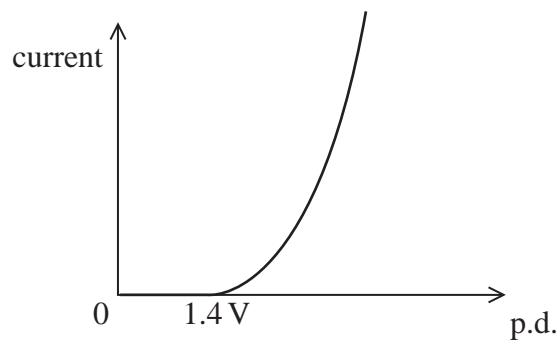

Explain how the behaviour of the LED shown in the graph will affect the time taken for the light intensity to decrease to zero.

(3)

- (c) The student states:

“A capacitor is being used in this circuit. The function of the capacitor is to store electric charge.”

Explain why this is not a complete description of the function of a capacitor.

(3)

(Total for Question 17 = 10 marks)



18 The photograph shows a demonstration a.c. generator used in a school.

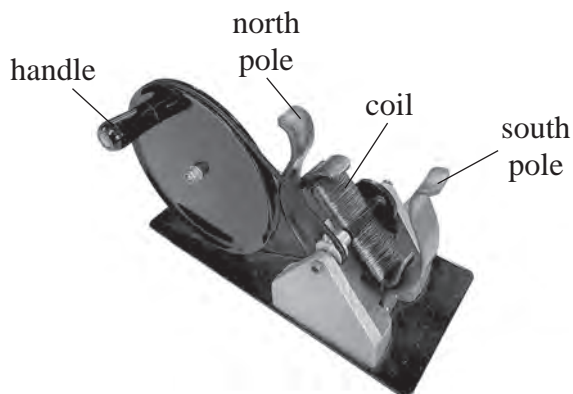

The handle is used to rotate the coil between the magnetic poles.
When a light emitting diode (LED) is connected across the coil, the LED flashes on and off as the coil rotates.

(a) Explain this observation.

(4)

.....

.....

.....

.....

.....

.....

.....

.....

.....

.....

DO NOT WRITE IN THIS AREA

DO NOT WRITE IN THIS AREA

DO NOT WRITE IN THIS AREA



(b) The output potential difference V for the generator is recorded using a data logger and a graph is produced of V against time t .

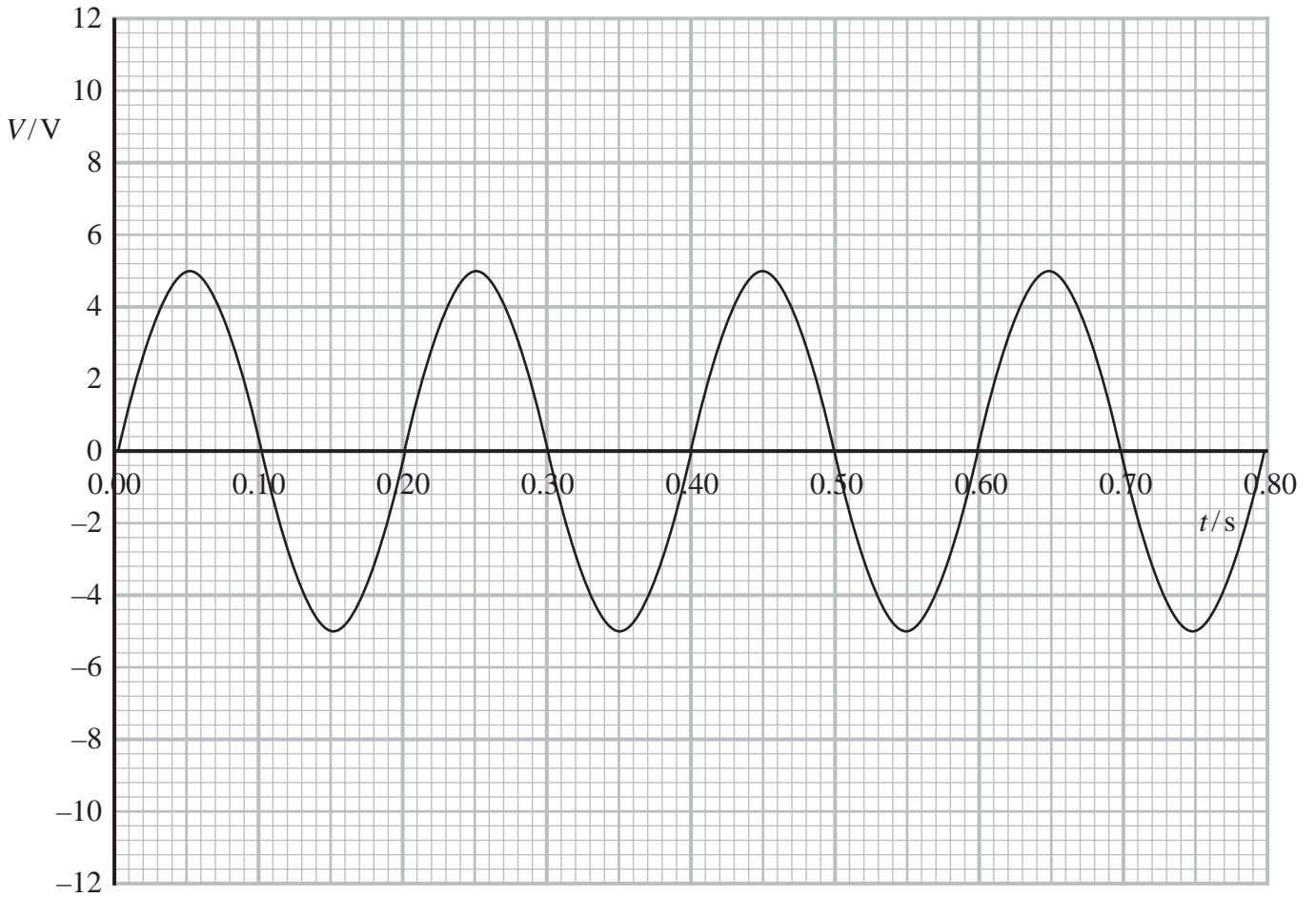

(i) Add to the graph to show the output if the angular velocity of the generator coil is halved.

(2)

(ii) Explain the changes in the graph when the angular velocity of the coil is halved.

(2)

.....

.....

.....

.....

.....



Turn over



DO NOT WRITE IN THIS AREA

DO NOT WRITE IN THIS AREA

DO NOT WRITE IN THIS AREA

(iii) The coil rotates in a uniform magnetic field at the original angular velocity.
The average magnitude of V is 3.2 V.

Determine the number of turns in the coil.

magnetic flux density = 0.083 T

cross-sectional area of coil = 0.0048 m²

(4)

Number of turns =

(Total for Question 18 = 12 marks)

DO NOT WRITE IN THIS AREA

DO NOT WRITE IN THIS AREA

DO NOT WRITE IN THIS AREA



19 The first cyclotron was created by E O Lawrence in 1931.

Lawrence obtained an expression for the time t for a particle of charge q and mass m to complete a circular path in a uniform magnetic field of magnetic flux density B .

The expression obtained by Lawrence is

$$t = \frac{2\pi m}{Bq}$$

(a) (i) Derive this expression.

(3)

(ii) In Lawrence's cyclotron, an alternating potential difference was used to accelerate particles to high energies.

Explain the significance of the expression obtained by Lawrence to the operation of a cyclotron.

(4)



(b) In a cyclotron, in which Lawrence's expression applies, protons were accelerated to a speed of $1.5 \times 10^7 \text{ ms}^{-1}$.

Determine the time taken to accelerate a proton to this speed from rest.

magnetic flux density = 1.6 T

accelerating potential difference = 13 kV

(5)

Time =

(c) Explain why high energy particles are required to investigate the structure of nucleons.

(3)

(Total for Question 19 = 15 marks)

TOTAL FOR SECTION B = 80 MARKS

TOTAL FOR PAPER = 90 MARKS



DO NOT WRITE IN THIS AREA

DO NOT WRITE IN THIS AREA

DO NOT WRITE IN THIS AREA

BLANK PAGE



P 6 0 4 9 3 A 0 2 5 2 8



List of data, formulae and relationships

Acceleration of free fall	$g = 9.81 \text{ m s}^{-2}$	(close to Earth's surface)
Boltzmann constant	$k = 1.38 \times 10^{-23} \text{ J K}^{-1}$	
Coulomb's law constant	$k = 1/4\pi\epsilon_0$ $= 8.99 \times 10^9 \text{ N m}^2 \text{ C}^{-2}$	
Electron charge	$e = -1.60 \times 10^{-19} \text{ C}$	
Electron mass	$m_e = 9.11 \times 10^{-31} \text{ kg}$	
Electronvolt	$1 \text{ eV} = 1.60 \times 10^{-19} \text{ J}$	
Gravitational constant	$G = 6.67 \times 10^{-11} \text{ N m}^2 \text{ kg}^{-2}$	
Gravitational field strength	$g = 9.81 \text{ N kg}^{-1}$	(close to Earth's surface)
Permittivity of free space	$\epsilon_0 = 8.85 \times 10^{-12} \text{ F m}^{-1}$	
Planck constant	$h = 6.63 \times 10^{-34} \text{ J s}$	
Proton mass	$m_p = 1.67 \times 10^{-27} \text{ kg}$	
Speed of light in a vacuum	$c = 3.00 \times 10^8 \text{ m s}^{-1}$	
Stefan-Boltzmann constant	$\sigma = 5.67 \times 10^{-8} \text{ W m}^{-2} \text{ K}^{-4}$	
Unified atomic mass unit	$u = 1.66 \times 10^{-27} \text{ kg}$	

Unit 1

Mechanics

Kinematic equations of motion	$v = u + at$ $s = ut + \frac{1}{2}at^2$ $v^2 = u^2 + 2as$
Forces	$\Sigma F = ma$ $g = F/m$ $W = mg$
Work and energy	$\Delta W = F\Delta s$ $E_k = \frac{1}{2}mv^2$ $\Delta E_{\text{grav}} = mg\Delta h$

Materials

Stokes' law	$F = 6\pi\eta rv$
Hooke's law	$F = k\Delta x$
Density	$\rho = m/V$
Pressure	$p = F/A$
Young modulus	$E = \sigma/\epsilon$ where Stress $\sigma = F/A$ Strain $\epsilon = \Delta x/x$
Elastic strain energy	$E_{\text{el}} = \frac{1}{2}F\Delta x$

DO NOT WRITE IN THIS AREA

DO NOT WRITE IN THIS AREA

DO NOT WRITE IN THIS AREA



Unit 2*Waves*Wave speed $v = f\lambda$ Refractive index ${}_1\mu_2 = \sin i / \sin r = v_1 / v_2$ *Electricity*Potential difference $V = W/Q$ Resistance $R = V/I$

Electrical power, energy and efficiency

$$P = VI$$

$$P = I^2R$$

$$P = V^2/R$$

$$W = VI t$$

$$\% \text{ efficiency} = \frac{\text{useful energy output}}{\text{total energy input}} \times 100$$

$$\% \text{ efficiency} = \frac{\text{useful power output}}{\text{total power input}} \times 100$$

Resistivity $R = \rho l/A$

Current

$$I = \Delta Q / \Delta t$$

$$I = nqvA$$
Resistors in series $R = R_1 + R_2 + R_3$ Resistors in parallel $\frac{1}{R} = \frac{1}{R_1} + \frac{1}{R_2} + \frac{1}{R_3}$ *Quantum physics*Photon model $E = hf$ Einstein's photoelectric equation $hf = \phi + \frac{1}{2}mv_{\max}^2$ 

Unit 4

Mechanics

Momentum	$p = mv$
Kinetic energy of a non-relativistic particle	$E_k = p^2/2m$
Motion in a circle	$v = \omega r$ $T = 2\pi/\omega$ $F = ma = mv^2/r$ $a = v^2/r$ $a = r\omega^2$

Fields

Coulomb's law	$F = kQ_1Q_2/r^2$ where $k = 1/4\pi\epsilon_0$
Electric field	$E = F/Q$ $E = kQ/r^2$ $E = V/d$
Capacitance	$C = Q/V$
Energy stored in capacitor	$W = \frac{1}{2}QV$
Capacitor discharge	$Q = Q_0 e^{-t/RC}$
In a magnetic field	$F = BIl \sin \theta$ $F = Bqv \sin \theta$ $r = p/BQ$
Faraday's and Lenz's laws	$\epsilon = -d(N\phi)/dt$

Particle physics

Mass-energy	$\Delta E = c^2 \Delta m$
de Broglie wavelength	$\lambda = h/p$

DO NOT WRITE IN THIS AREA

DO NOT WRITE IN THIS AREA

DO NOT WRITE IN THIS AREA

