

Please check the examination details below before entering your candidate information

Candidate surname

Other names

Centre Number

Candidate Number

--	--	--	--	--

--	--	--	--	--

Pearson Edexcel International Advanced Level

Time 1 hour 45 minutes

Paper
reference

WBI14/01

Biology

International Advanced Level

Unit 4: Energy, Environment, Microbiology and
Immunity

You must have:

Scientific calculator, ruler, HB pencil

Total Marks

Instructions

- Use **black** ink or ball-point pen.
- **Fill in the boxes** at the top of this page with your name, centre number and learner registration number.
- Answer **all** questions.
- Answer the questions in the spaces provided – *there may be more space than you need.*
- Calculators may be used.
- You must **show all your working out** with **your answer clearly identified** at the **end of your solution.**

Information

- The total mark for this paper is 90.
- The marks for **each** question are shown in brackets – *use this as a guide as to how much time to spend on each question.*
- Any diagrams may NOT be accurately drawn, unless otherwise indicated.
- In questions marked with an **asterisk** (*), marks will be awarded for your ability to structure your answer logically showing how the points that you make are related or follow on from each other where appropriate.

Advice

- Read each question carefully before you start to answer it.
- Try to answer every question.
- Check your answers if you have time at the end.

Turn over ►

P67105A

©2021 Pearson Education Ltd.

E:1/1/1/1/1/1/



Pearson

Answer ALL questions. Write your answers in the spaces provided.

Some questions must be answered with a cross in a box ☒. If you change your mind about an answer, put a line through the box ☒ and then mark your new answer with a cross ☒.

1 The structure of a chloroplast is related to its role in photosynthesis.

The diagram shows a chloroplast.

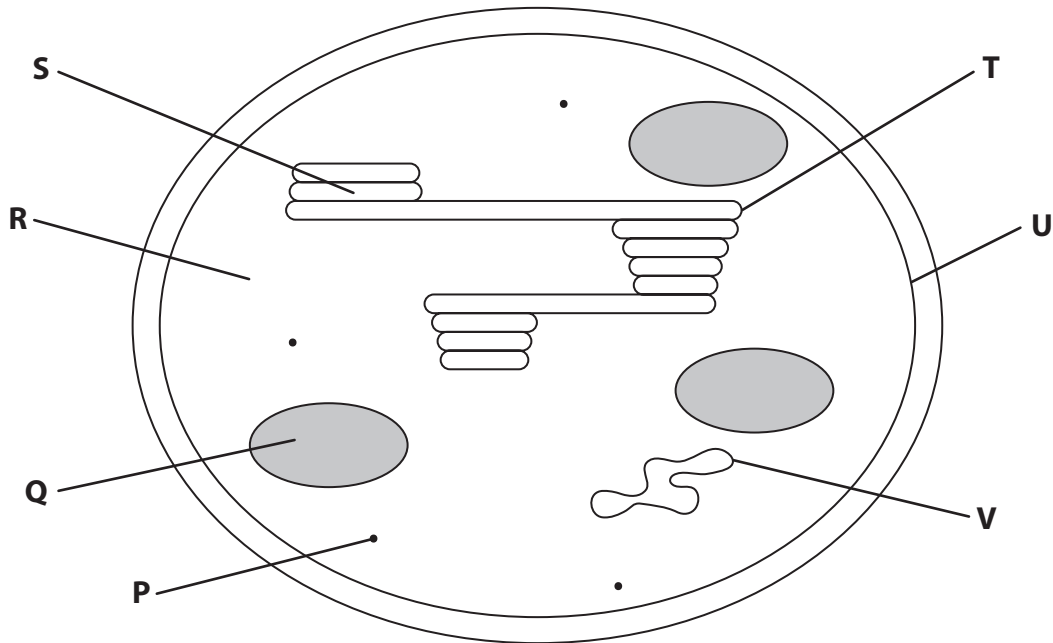

(a) (i) Which row in the table identifies the structures labelled **P**, **Q** and **V**?

(1)

	P	Q	V
<input type="checkbox"/> A	DNA	starch grain	ribosome
<input type="checkbox"/> B	starch grain	DNA	ribosome
<input type="checkbox"/> C	starch grain	ribosome	DNA
<input type="checkbox"/> D	ribosome	starch grain	DNA



(ii) Which structure contains GALP?

(1)

- A Q
- B R
- C U
- D V

(iii) The length of this chloroplast is $7.5\ \mu\text{m}$.

Calculate the magnification of this diagram.

(1)

Answer

(iv) Structures **T** and **U** are membranes.

Compare and contrast the structure of these two membranes.

(3)

.....

.....

.....

.....

.....

.....

.....

.....

.....

.....

DO NOT WRITE IN THIS AREA

DO NOT WRITE IN THIS AREA

DO NOT WRITE IN THIS AREA



P 6 7 1 0 5 A 0 3 3 6



Turn over

- (b) An investigation studied the effect of periods of light and dark on the levels of chloroplast DNA in one species of a single-celled organism.

One group of these organisms, group A, was exposed to 36 hours of continuous light.

The other group of these organisms, group B, was exposed to 12 hours of light, followed by 12 hours of darkness, followed by 12 hours of light.

The graph shows the results of this investigation.

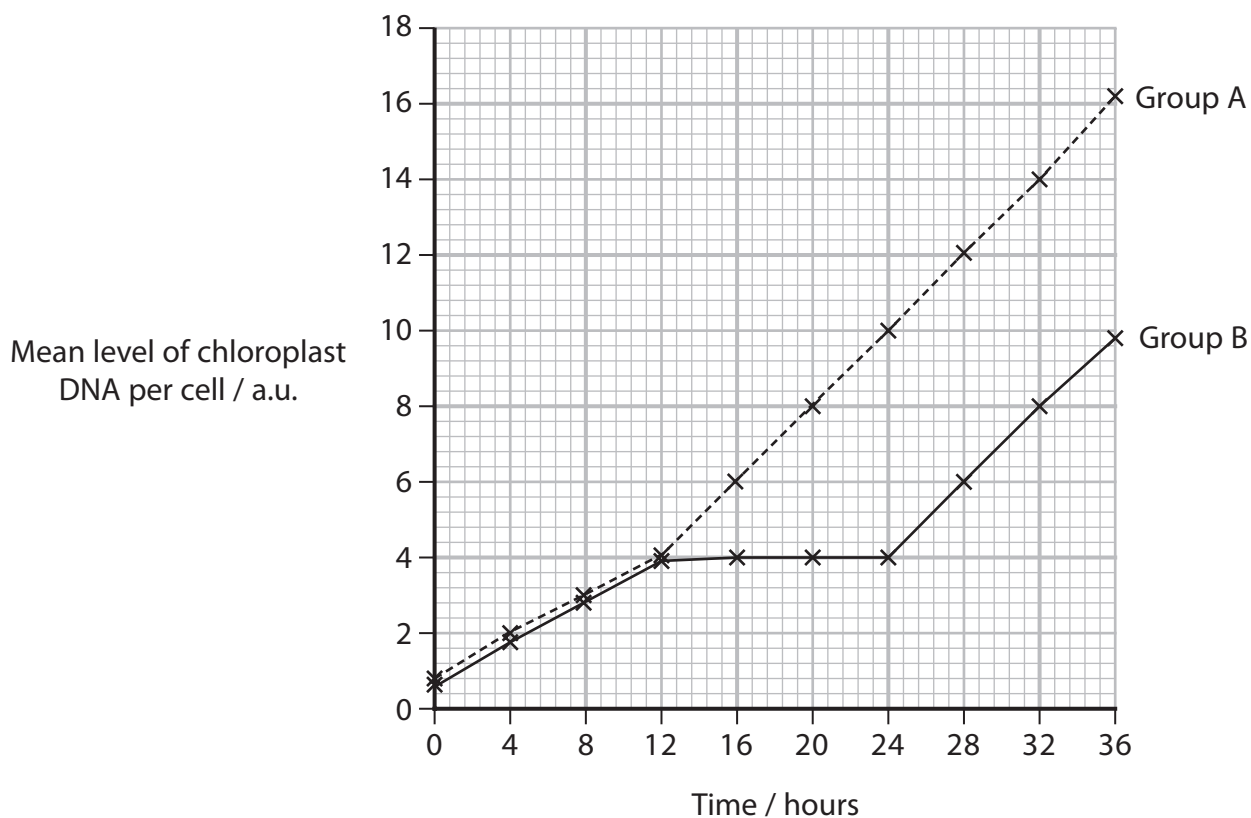

These organisms divide by mitosis followed by cell division, during the dark.

Describe two conclusions that can be made about the replication of chloroplast DNA.

(2)

.....

.....

.....

.....

.....

.....

.....

(Total for Question 1 = 8 marks)



DO NOT WRITE IN THIS AREA

DO NOT WRITE IN THIS AREA

DO NOT WRITE IN THIS AREA

2 Rabies is a disease caused by a virus.

(a) The diagram shows the structure of the rabies virus.

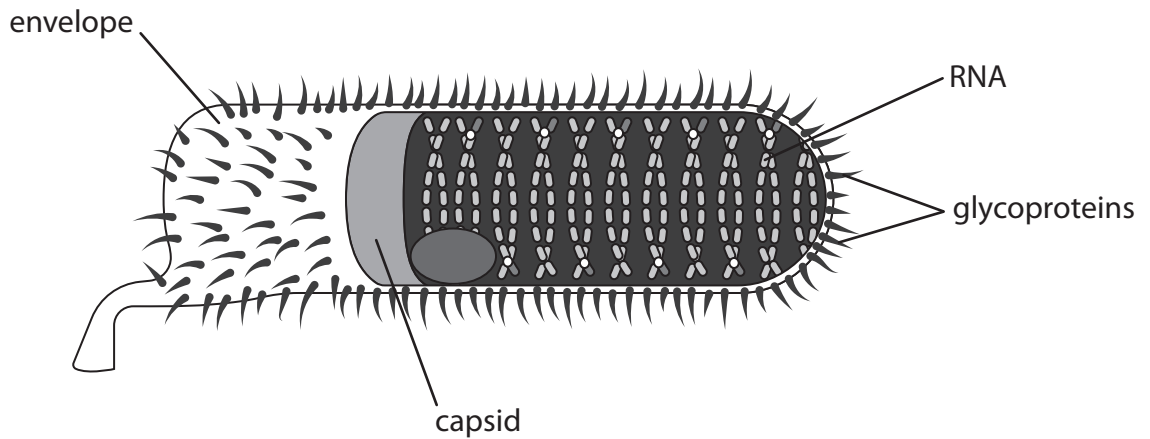

(i) The rabies virus has an envelope.

Which of the following pairs of viruses have an envelope?

(1)

- A Ebola virus and human immunodeficiency virus (HIV)
- B human immunodeficiency virus (HIV) and tobacco mosaic virus (TMV)
- C lambda phage (λ phage) and Ebola virus
- D tobacco mosaic virus (TMV) and lambda phage (λ phage)

(ii) The structure of the rabies capsid is described as complex.

Which of the following has a complex capsid structure?

(1)

- A Ebola virus
- B human immunodeficiency virus (HIV)
- C lambda phage (λ phage)
- D tobacco mosaic virus (TMV)



(iii) Rabies virus is an RNA virus.

How many of the following viruses are RNA viruses?

- Ebola virus
- human immunodeficiency virus (HIV)
- lambda phage (λ phage)
- tobacco mosaic virus (TMV)

(1)

- A 1
- B 2
- C 3
- D 4

(b) The rabies virus replicates in a lytic cycle.

The RNA of the rabies virus is a negative RNA strand.

The diagram shows how the negative RNA strand of the rabies virus is used to make positive RNA and proteins.

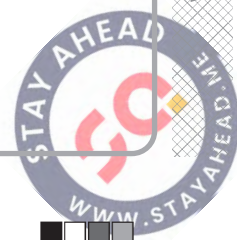
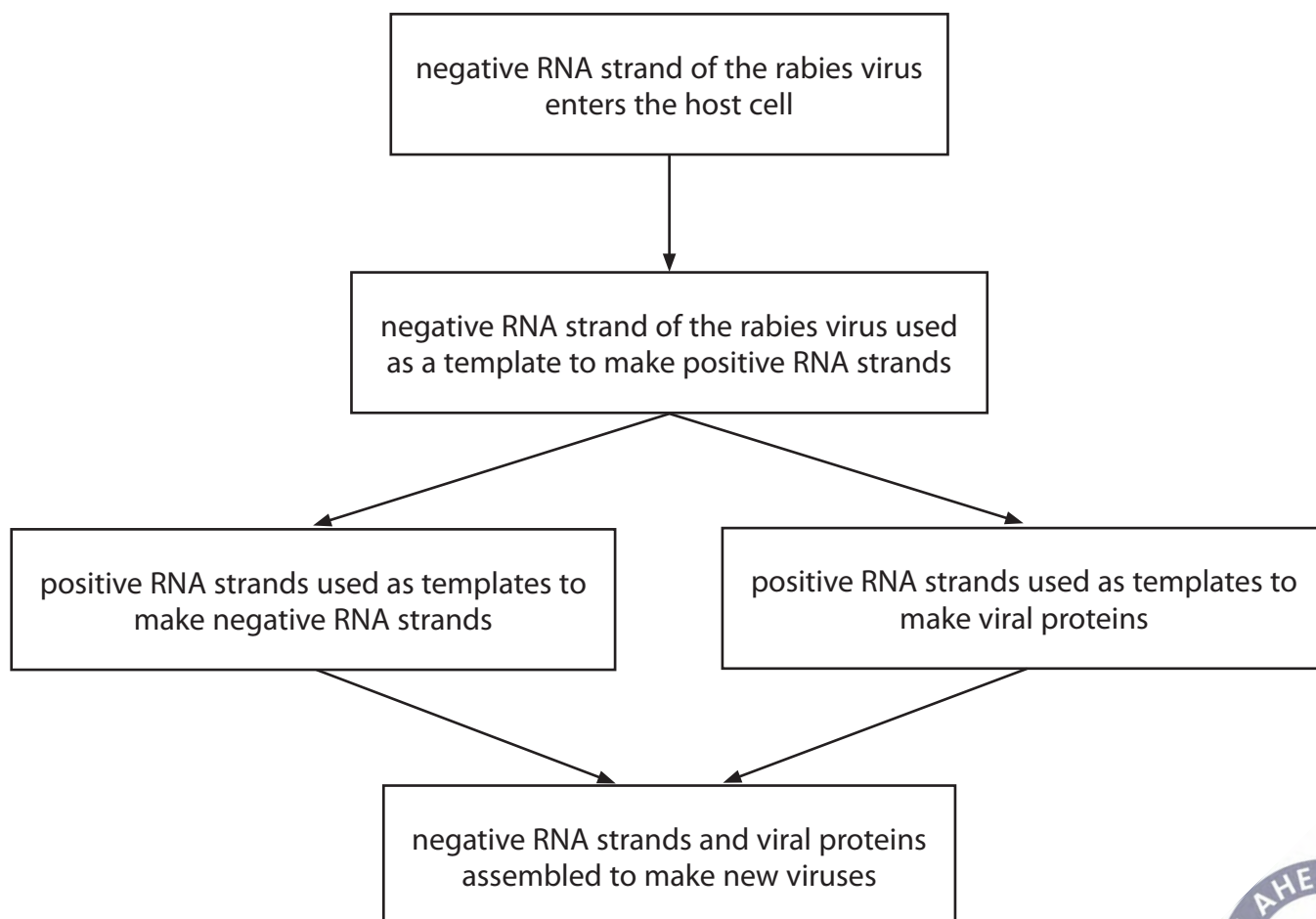

(i) The diagram shows part of the base sequence in the negative RNA strand.

Complete the diagram to show the corresponding base sequence in the positive RNA strand.

(1)

Negative RNA strand	A	C	C	A	A	G	G	C	G
Positive RNA strand									

(ii) Explain why a positive RNA strand has to be made.

(2)

.....

.....

.....

.....

.....

.....

DO NOT WRITE IN THIS AREA

DO NOT WRITE IN THIS AREA

DO NOT WRITE IN THIS AREA



P 6 7 1 0 5 A 0 7 3 6



Turn over

(c) Lemurs are found in Madagascar. It is thought that they might carry rabies viruses.
The photograph shows a lemur.



(Source: Caroline Wilcox)

A person was bitten by a lemur.

This person did not receive any treatment for rabies until 18 days after being bitten.

Explain why doctors were worried that this person had left it too long for the treatment to be successful.

(4)

.....

.....

.....

.....

.....

.....

.....

.....

.....

.....

.....

.....

.....

.....

.....

.....

.....

.....

.....

.....

.....

.....

.....

(Total for Question 2 = 10 marks)

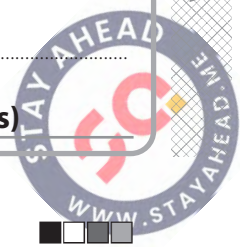

DO NOT WRITE IN THIS AREA

DO NOT WRITE IN THIS AREA

DO NOT WRITE IN THIS AREA

4 Redwood trees are the tallest living organisms on Earth. Some of the older trees are more than 2000 years old.

Dendrochronology can be used to work out how old a tree is and how much it has grown each year.

A sample of the tree trunk core can be taken using an increment borer.

The photograph shows an increment borer being used to take a sample of a tree trunk core.



(Source: © Custom Life Science Images / Alamy Stock Photo)



- (a) The diagram shows an increment borer pushed into the trunk of a large Redwood tree.

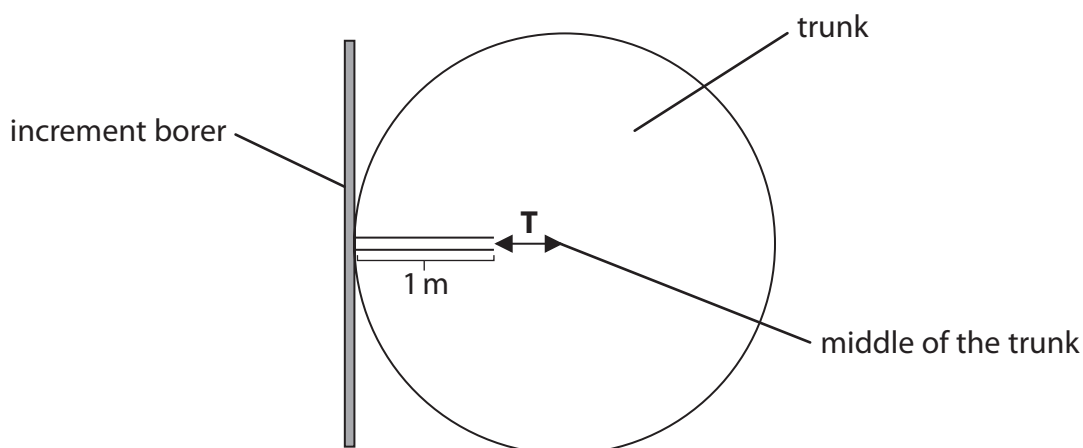

An increment borer 1 m long was inserted into a Redwood tree. The borer did not reach the middle of the trunk. The distance from the end of the borer to the middle of the trunk is **T** cm.

- (i) Calculate the radius (r) of a tree with a circumference (C) of 8 m.

Use the formula: $r = \frac{C}{2\pi}$

Give your answer to **two** decimal places.

(1)

Answer m

- (ii) Calculate the distance **T** as a percentage of this radius.

(1)

Answer %



- (b) To calculate how old a tree is and how much it has grown, core samples are taken at different heights up the tree.

These core samples are then aligned by matching the rings, as shown in the diagram.

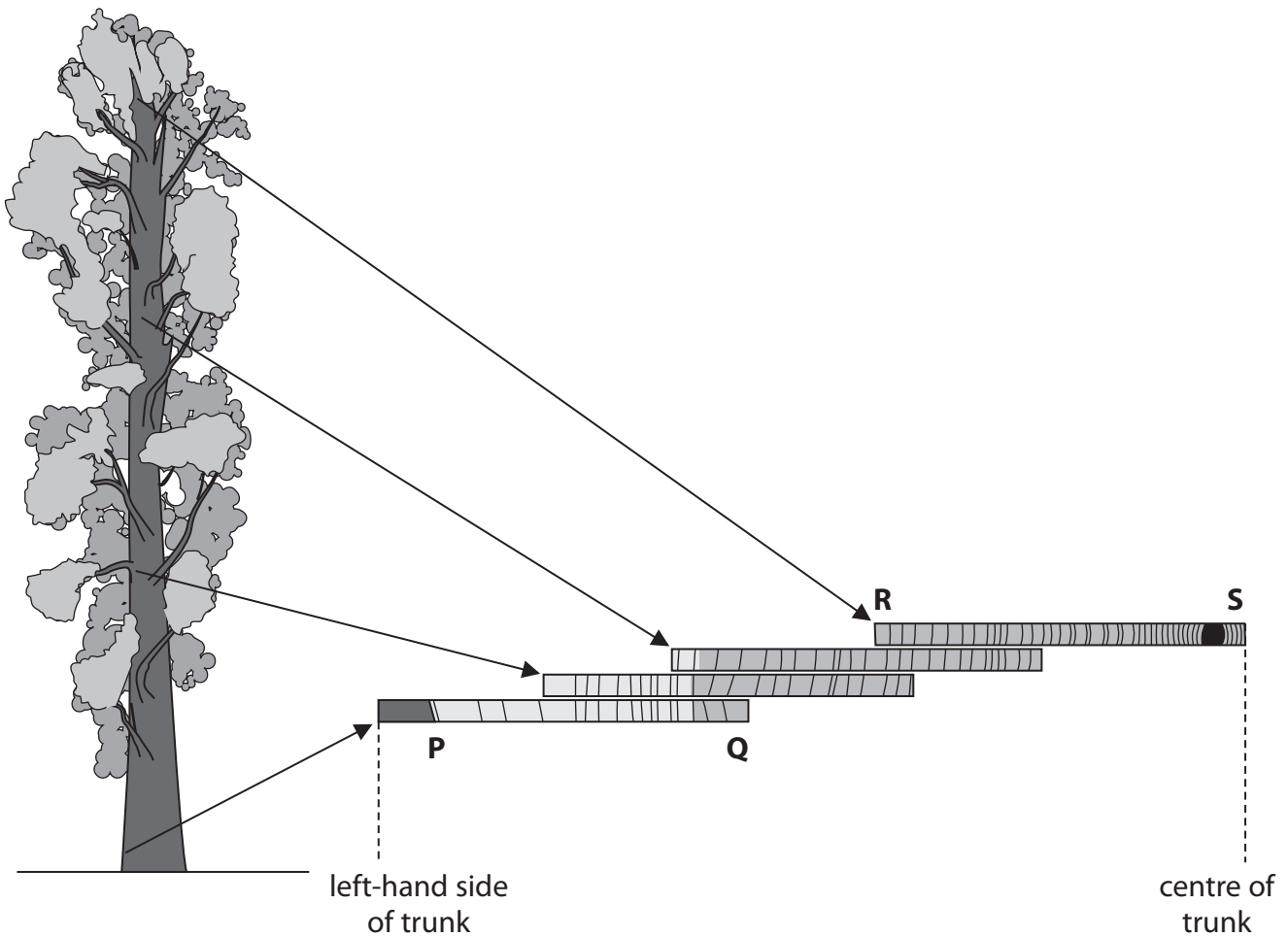

- (i) Which row of the table shows the newest and oldest rings in this tree?

(1)

		newest ring	oldest ring
<input checked="" type="checkbox"/>	A	P	Q
<input checked="" type="checkbox"/>	B	P	S
<input checked="" type="checkbox"/>	C	S	R
<input checked="" type="checkbox"/>	D	S	P



P 6 7 1 0 5 A 0 1 3 3 6

(ii) Explain how these core samples can be used to calculate the age of this tree.
Use the information in the question and the diagram to support your answer.

(3)

.....

.....

.....

.....

.....

.....

.....

.....

.....

.....

.....

(iii) Describe how the growth rate of this tree can be calculated.

(2)

.....

.....

.....

.....

.....

.....

.....

.....

.....

.....

(Total for Question 4 = 8 marks)

DO NOT WRITE IN THIS AREA

DO NOT WRITE IN THIS AREA

DO NOT WRITE IN THIS AREA



DO NOT WRITE IN THIS AREA

DO NOT WRITE IN THIS AREA

DO NOT WRITE IN THIS AREA

5 Antimicrobial substances can be tested using a Minimum Inhibitory Concentration (MIC) assay.

This assay determines the lowest concentration of an antimicrobial substance that prevents visible growth of bacteria.

A microdilution plate is used in these assays. It is made of plastic and contains small wells that the antimicrobial substance and the bacteria can be added to.

The diagram shows a microdilution plate.

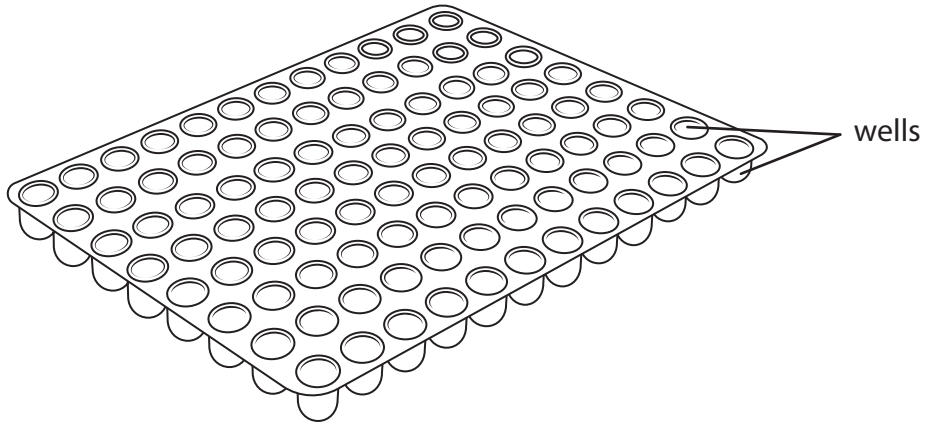

An investigation tested eight antimicrobial substances on one type of bacteria, *E. coli*.

Appropriate controls were included in this investigation.

The diagram shows the steps involved.

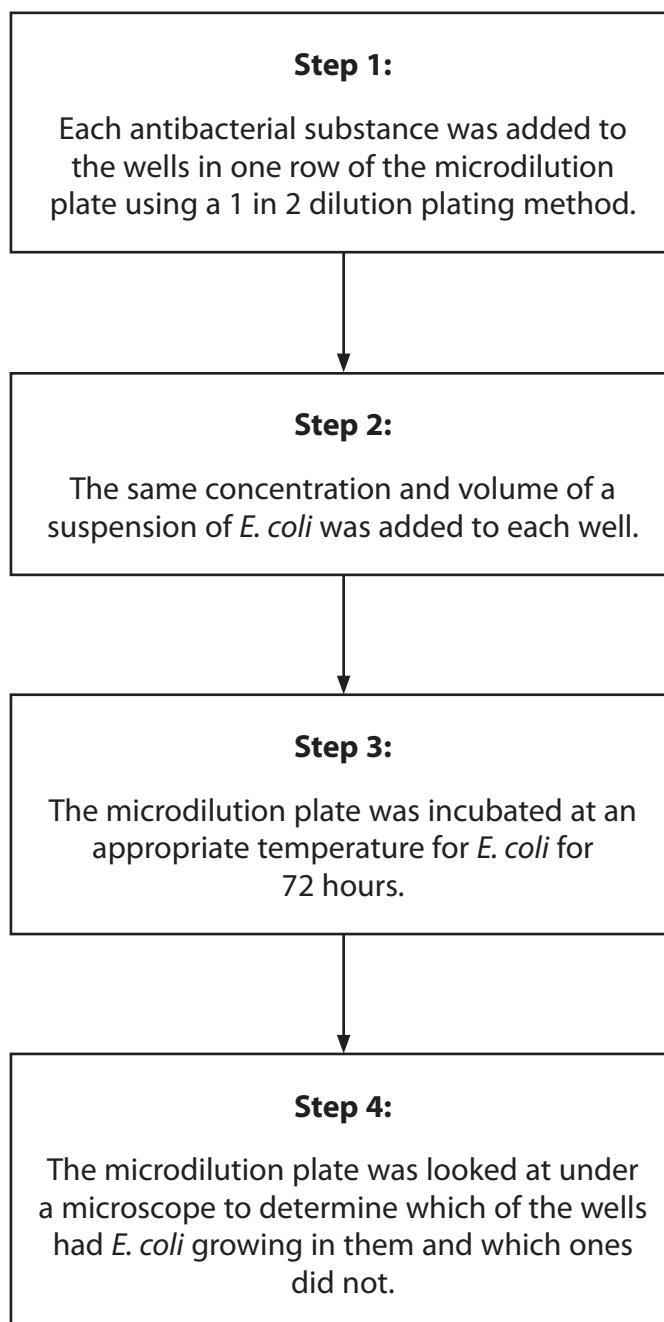

(a) All steps in this investigation had to be carried out using aseptic technique.

(i) State the meaning of the term **aseptic technique**. (1)

.....

.....

(ii) Describe two aseptic techniques that could be used in this investigation. (2)

.....

.....

.....

.....

.....

(iii) Explain why using aseptic technique in this investigation is important. (2)

.....

.....

.....

.....

.....

.....

.....

.....

.....



(b) Explain why the microdilution plate had to be incubated at an appropriate temperature for *E. coli* for 72 hours.

(2)

.....

.....

.....

.....

.....

.....

(c) The diagram shows the results of the MIC assay from this investigation.

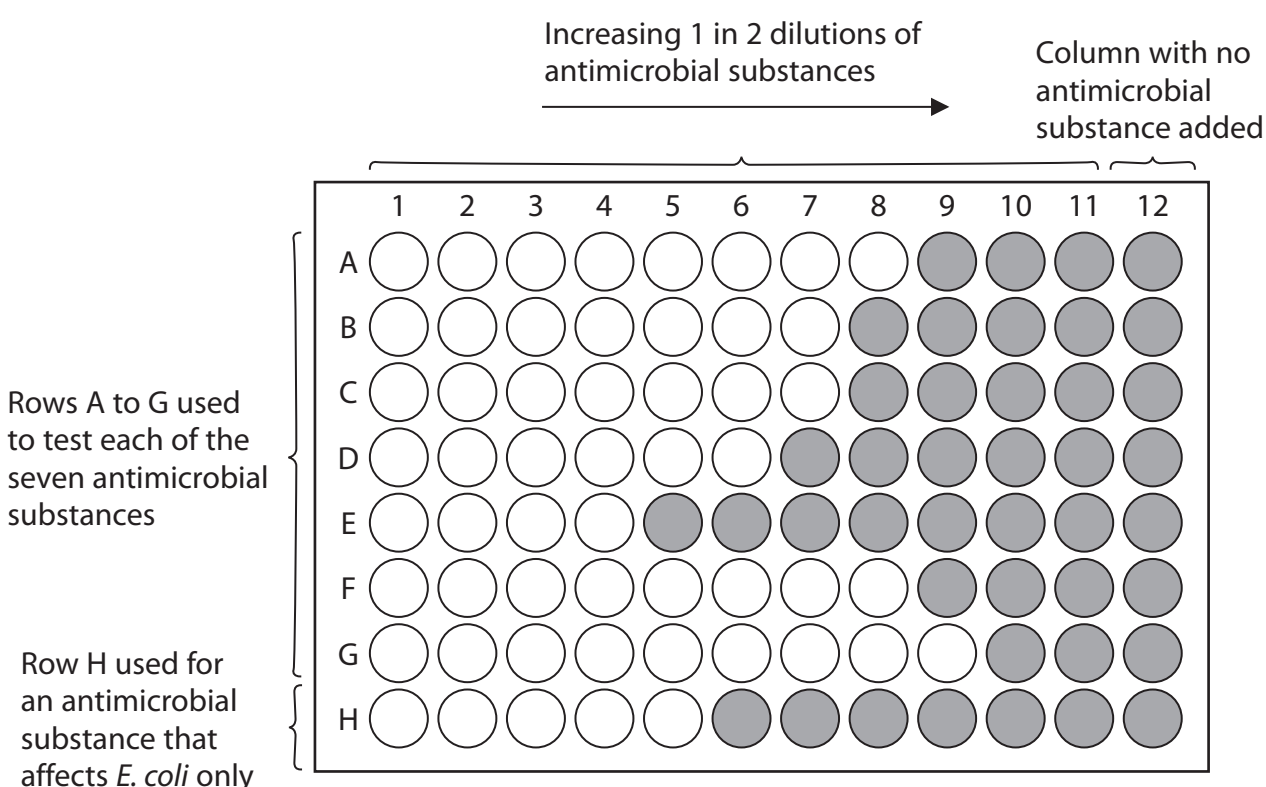

Key:

No growth of *E. coli* ○ Growth of *E. coli* ●



(i) Explain why an antimicrobial substance that affects *E. coli* only was included in this assay (row **H**).

(2)

(ii) Explain why there was one column that had no antimicrobial substance added to it (column 12).

(2)

(iii) The MIC for the antimicrobial substance used in row **E** was in column 4.

Describe how a 1 in 2 dilution plating method would have been carried out to achieve the dilution in this well.

(2)

DO NOT WRITE IN THIS AREA

DO NOT WRITE IN THIS AREA

DO NOT WRITE IN THIS AREA



P 6 7 1 0 5 A 0 1 9 3 6



(iv) Calculate how many times more effective the antimicrobial substance used in row **G** is than the antimicrobial substance used in row **E**.

(2)

Answer

(Total for Question 5 = 15 marks)

DO NOT WRITE IN THIS AREA

DO NOT WRITE IN THIS AREA

DO NOT WRITE IN THIS AREA

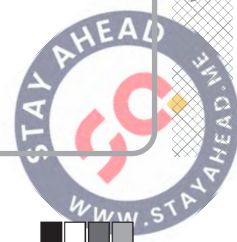

DO NOT WRITE IN THIS AREA

DO NOT WRITE IN THIS AREA

DO NOT WRITE IN THIS AREA

6 Seaweeds are a group of organisms that carry out photosynthesis.

Identifying the types and proportions of chlorophyll pigments is important in the classification of seaweeds and biodiversity studies.

(a) State the meaning of the term **biodiversity**. (2)

.....

.....

.....

.....

.....

.....

(b) Explain the role of chlorophyll in the light-dependent reactions of photosynthesis. (2)

.....

.....

.....

.....

.....

.....



DO NOT WRITE IN THIS AREA

DO NOT WRITE IN THIS AREA

DO NOT WRITE IN THIS AREA

- (c) An investigation compared the effectiveness of two solvents, propanone and DMSO, in extracting photosynthetic pigments.

Four species of seaweed were collected from the Indian coast of Tamil Nadu and taken to the laboratory where the species were identified.

Each species of seaweed was split into two samples of equal mass.

The photosynthetic pigments were extracted from each sample using one of the two solvents and their concentrations determined.



The graphs show some of the results of this investigation.

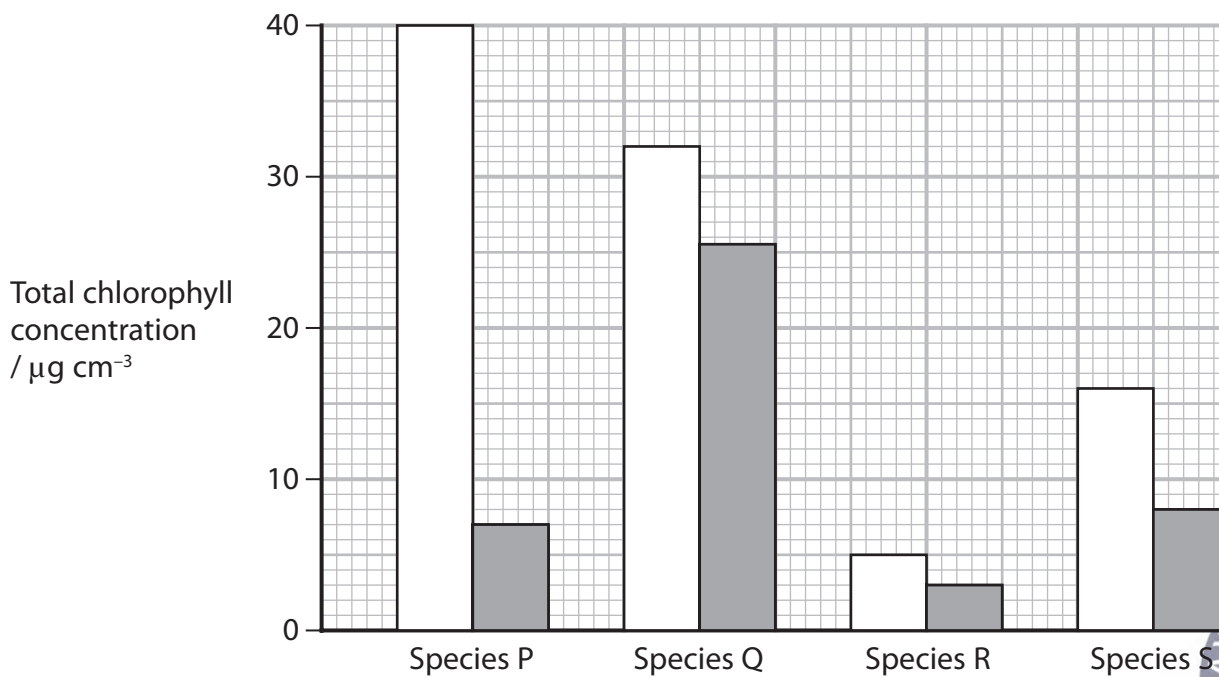
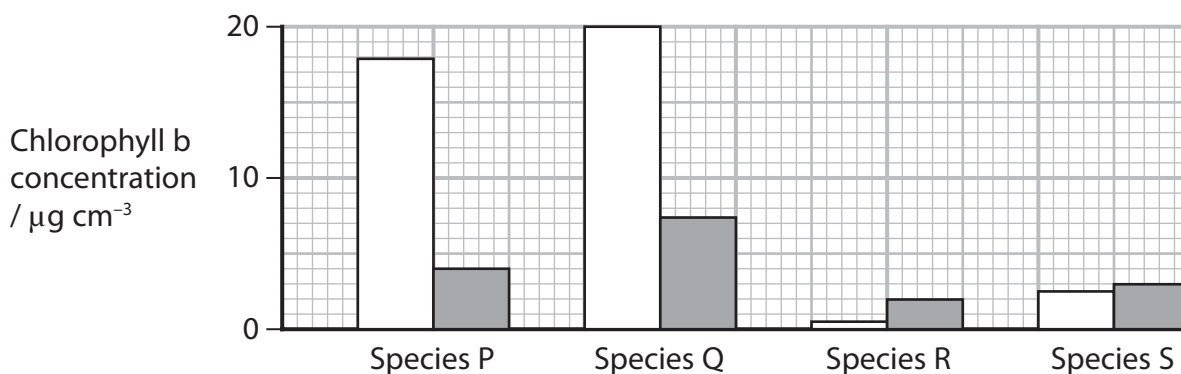
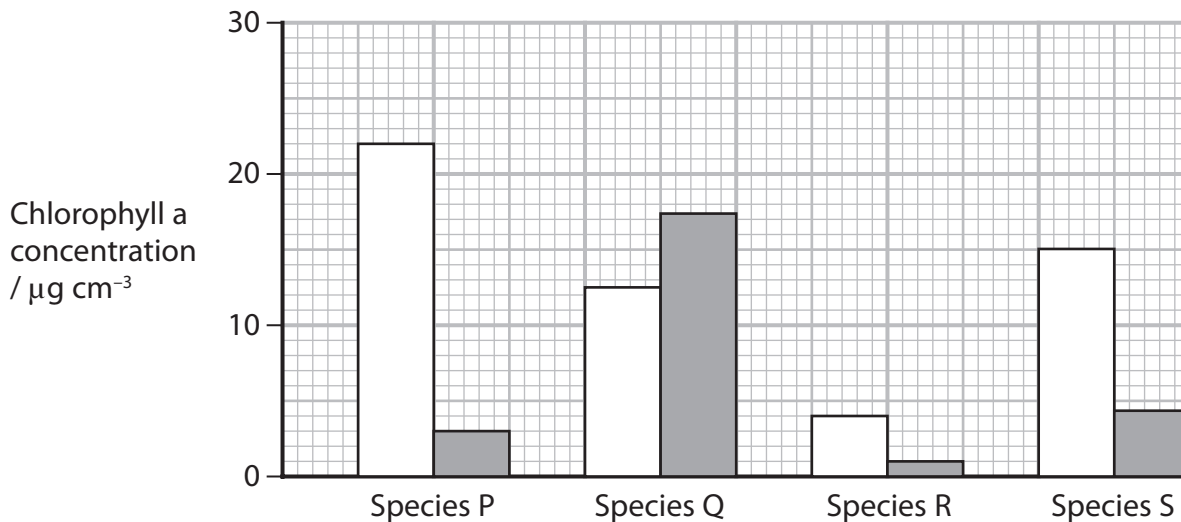
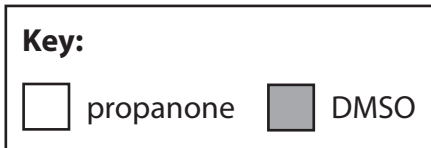

DO NOT WRITE IN THIS AREA

DO NOT WRITE IN THIS AREA

DO NOT WRITE IN THIS AREA



* (i) Discuss the effectiveness of these extraction methods in the identification of these species.

Use the information in the graphs to support your answer.

(6)

Area with horizontal dotted lines for writing the answer.

DO NOT WRITE IN THIS AREA

DO NOT WRITE IN THIS AREA

DO NOT WRITE IN THIS AREA



(ii) Suggest why different concentrations of chlorophyll were obtained using these two different solvents.

(2)

.....

.....

.....

.....

.....

.....

.....

(Total for Question 6 = 12 marks)

DO NOT WRITE IN THIS AREA

DO NOT WRITE IN THIS AREA

DO NOT WRITE IN THIS AREA



Turn over

7 Climate change is dependent on the balance of carbon released into the atmosphere and carbon removed from the atmosphere.

Some ecosystems are better than others at storing carbon in their soil, releasing less back into the atmosphere.

Conserving these ecosystems could be an important way of reducing climate change.

One study investigated the extent of decomposition in different ecosystems.

This study used tea in teabags as the source of organic matter for decomposition.

The photograph shows a teabag.



(Source: © Hugh Threlfall / Alamy Stock Photo)

DO NOT WRITE IN THIS AREA

DO NOT WRITE IN THIS AREA

DO NOT WRITE IN THIS AREA

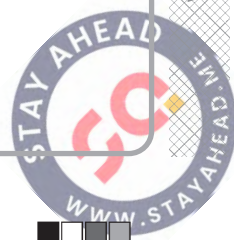

DO NOT WRITE IN THIS AREA

DO NOT WRITE IN THIS AREA

DO NOT WRITE IN THIS AREA

(a) The first part of the study was carried out in a laboratory.

Two types of tea were used, green tea and rooibos tea.

A number of unused teabags containing each type of tea were buried in soil at two different temperatures, 15°C and 25°C.

The mass of tea in each teabag had been determined before they were buried.

At regular intervals teabags were dug up, dried, and the remaining tea reweighed.

The graph shows the results of this study.

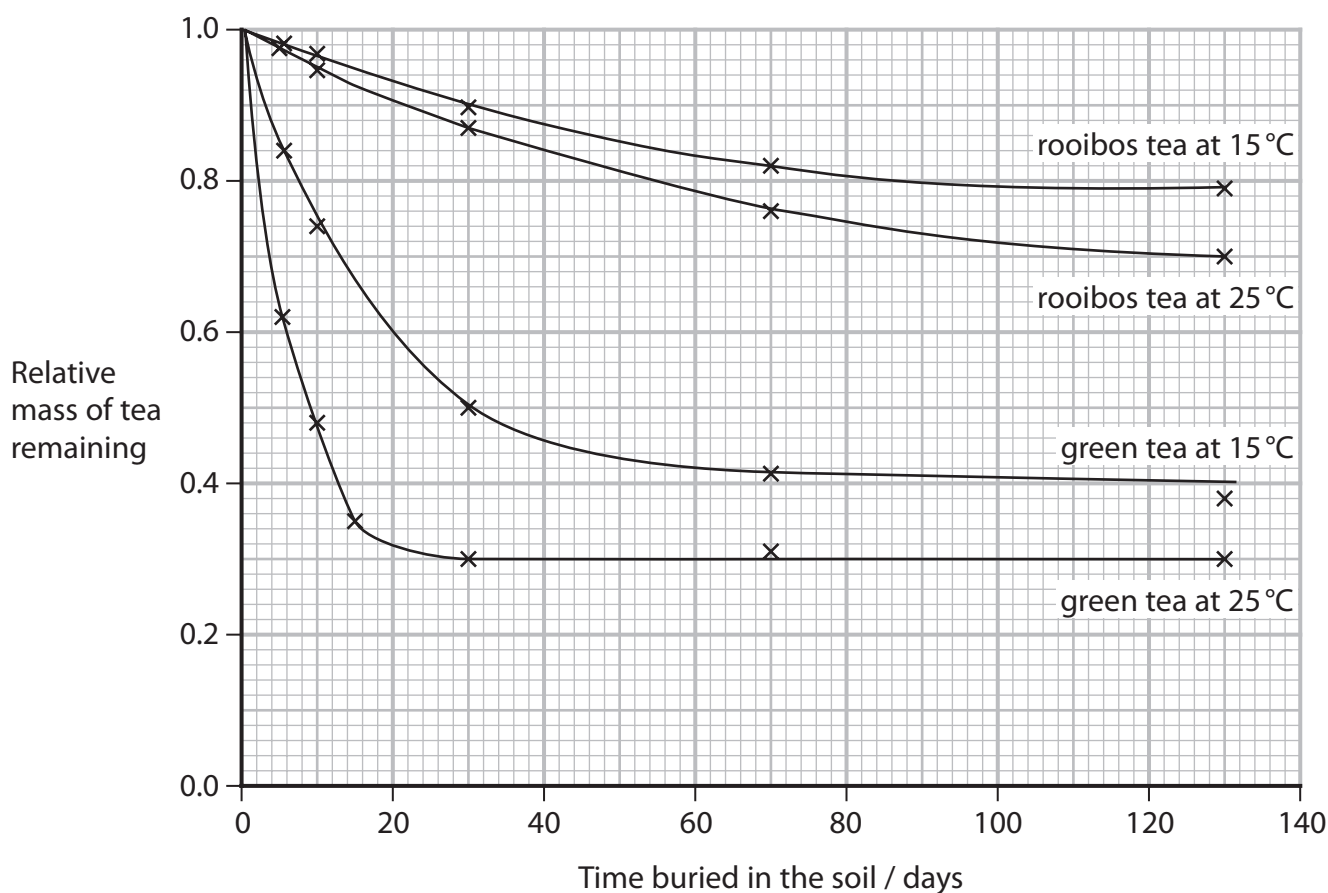

(i) The teabags had to be dried before weighing to remove water.

One teabag contained 28g of tea when it was buried. When it was dug up it had a wet mass of 42g. The water content of this teabag was calculated to be 50%.

Calculate the mass of organic matter lost during this study.

(1)

Answer g



Turn over



(iv) Suggest why the rate of decomposition of green tea was different from that of rooibos tea.

(2)

.....

.....

.....

.....

.....

.....

(b) In the second part of this study, several teabags were buried in different ecosystems.

The teabags were left buried for three months and then dug up.

A number of measurements were taken from the tea in these teabags and the mean decomposition rate and the mean stabilisation factor (S) calculated.

The higher the value of S, the more carbon is stored in the ecosystem.

The graph shows some of the results from this study.

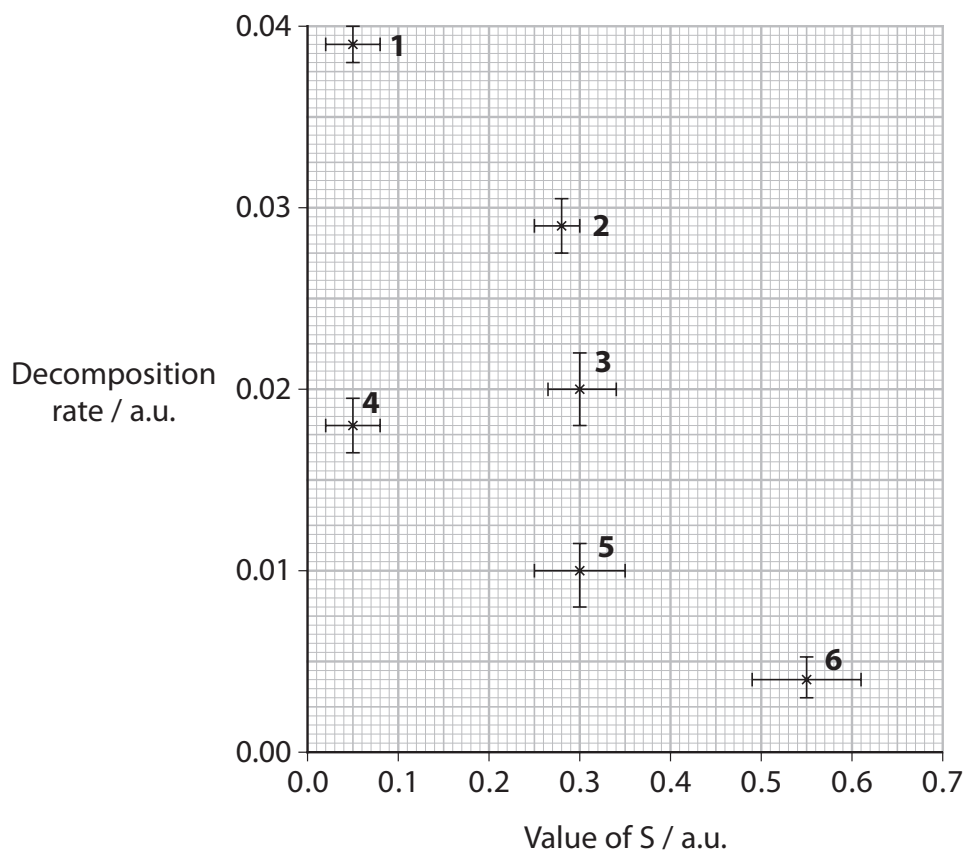

Key:

- 1 forest in Panama
- 2 mixed forest in Austria
- 3 birch forest in Austria
- 4 grassland in Iceland
- 5 sandy desert in China
- 6 loamy desert in China

DO NOT WRITE IN THIS AREA

DO NOT WRITE IN THIS AREA

DO NOT WRITE IN THIS AREA



(i) Suggest why each point on the graph has both a horizontal and a vertical error bar plotted with it.

(1)

.....

.....

.....

(ii) Explain which ecosystems should be conserved to have the greatest impact on climate change.

Use the information in the graph to support your answer.

(3)

.....

.....

.....

.....

.....

.....

.....

.....

.....

.....

.....

(Total for Question 7 = 13 marks)

DO NOT WRITE IN THIS AREA

DO NOT WRITE IN THIS AREA

DO NOT WRITE IN THIS AREA



8 Scientists studied the distribution of biomass in organisms on Earth.

(a) State the meaning of the term **biomass**.

(1)

(b) Voronoi diagrams were used to present some of the data.

Two Voronoi diagrams are shown.

Diagram A shows the biomasses of groups of organisms.

Diagram B shows the biomasses of the organisms in the animals group.

The biomass is given in gigatons of carbon (GtC), where $1 \text{ GtC} = 10^{15} \text{ g}$ of carbon.

Diagram A

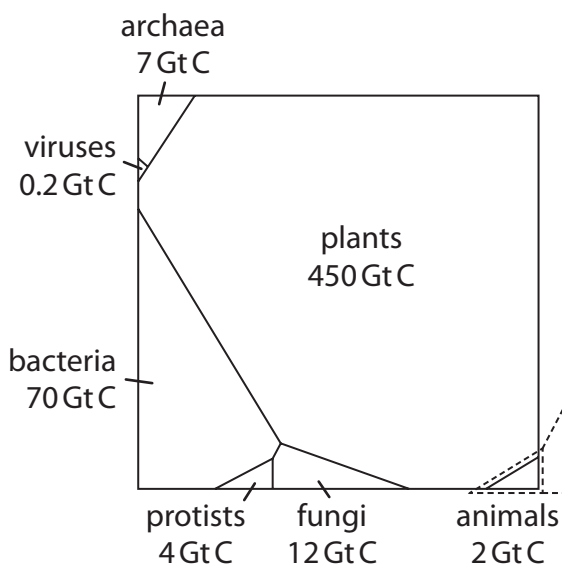
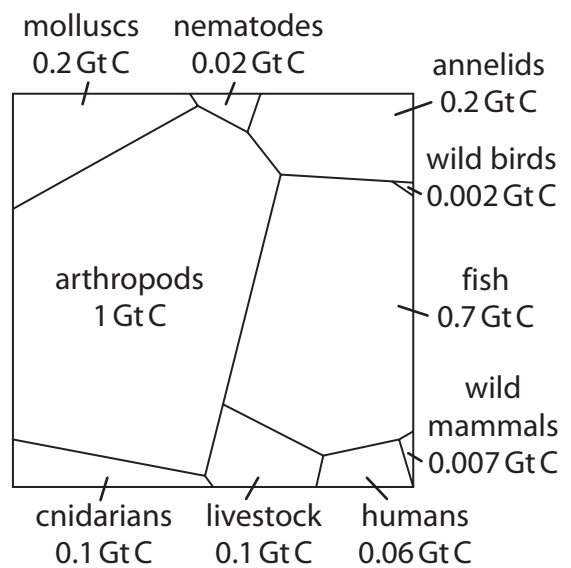

Diagram B



The area of each polygon is proportional to the biomass of that organism. The shape of each polygon has no meaning.



P 6 7 1 0 5 A 0 3 1 3 6

- (i) Calculate the percentage of biomass in organisms belonging to the domain Eukarya.

Use the information in diagram A.

(2)

Answer %

- (ii) Suggest why the scientists studied the distribution of biomass in groups of organisms and not the number of individual organisms.

Use the information in diagram A.

(2)

.....

.....

.....

.....

.....

.....

- (iii) Discuss the advantages and disadvantages of presenting data in Voronoi diagrams.

Use diagram B to support your answer.

(3)

.....

.....

.....

.....

.....

.....

.....

.....

.....

.....

.....



DO NOT WRITE IN THIS AREA

DO NOT WRITE IN THIS AREA

DO NOT WRITE IN THIS AREA

*(c) The same study also determined the distribution of biomass in three different environments: marine, deep underground and land.

The Voronoi diagram shows the distribution of biomass in each environment.

The graph shows the proportion of biomass in different groups of organisms.

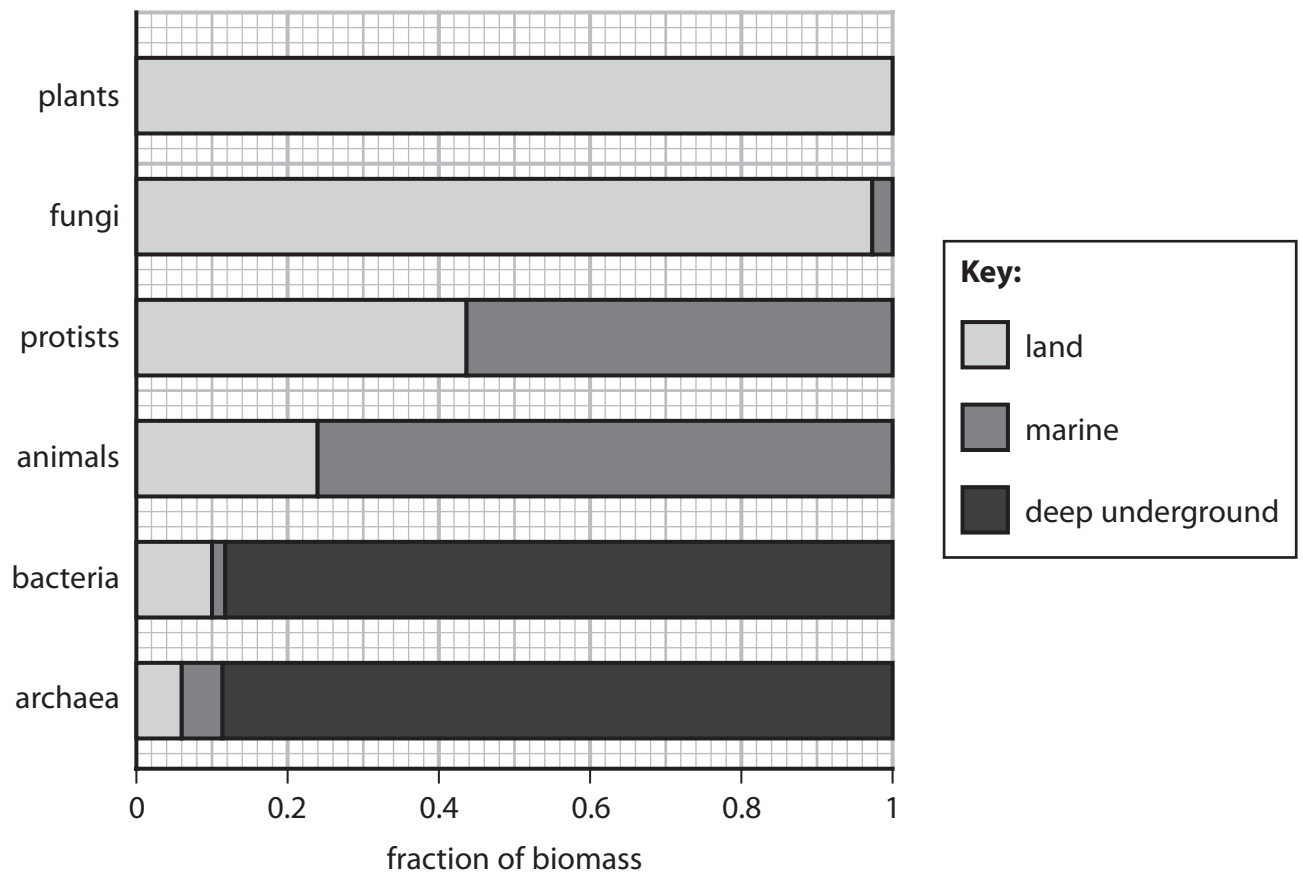
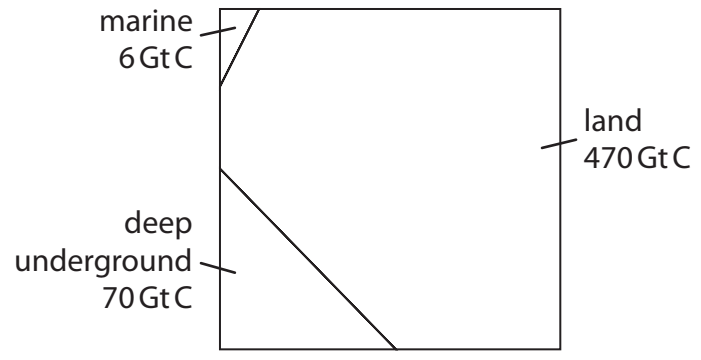

Explain the distribution of biomass in these three environments.

Use the information in the Voronoi diagram and the graph to support your answer.

(6)

Area with horizontal dotted lines for writing the answer.

(Total for Question 8 = 14 marks)

TOTAL FOR PAPER = 90 MARKS

DO NOT WRITE IN THIS AREA

DO NOT WRITE IN THIS AREA

DO NOT WRITE IN THIS AREA



DO NOT WRITE IN THIS AREA

DO NOT WRITE IN THIS AREA

DO NOT WRITE IN THIS AREA

BLANK PAGE



P 6 7 1 0 5 A 0 3 5 3 6



DO NOT WRITE IN THIS AREA

DO NOT WRITE IN THIS AREA

DO NOT WRITE IN THIS AREA

BLANK PAGE

