



Cambridge International AS & A Level

CANDIDATE
NAME

--

CENTRE
NUMBER

--	--	--	--	--

CANDIDATE
NUMBER

--	--	--	--



COMPUTER SCIENCE

9618/31

Paper 3 Advanced Theory

May/June 2021

1 hour 30 minutes

You must answer on the question paper.

No additional materials are needed.

INSTRUCTIONS

- Answer **all** questions.
- Use a black or dark blue pen.
- Write your name, centre number and candidate number in the boxes at the top of the page.
- Write your answer to each question in the space provided.
- Do **not** use an erasable pen or correction fluid.
- Do **not** write on any bar codes.
- You may use an HB pencil for any diagrams, graphs or rough working.
- Calculators must **not** be used in this paper.

INFORMATION

- The total mark for this paper is 75.
- The number of marks for each question or part question is shown in brackets [].
- No marks will be awarded for using brand names of software packages or hardware.

This document has **12** pages.

1 Real numbers are stored in a computer system using floating-point representation with:

- 10 bits for the mantissa
- 6 bits for the exponent
- Two's complement form for both the mantissa and the exponent.

(a) Calculate the normalised floating-point representation of -7.25 in this system. Show your working.

Mantissa

Exponent

--	--	--	--	--	--	--	--	--	--

--	--	--	--	--	--

Working

.....

.....

.....

.....

.....

.....

.....

.....

.....

[3]

(b) Calculate the denary value of the given binary floating-point number. Show your working.

Mantissa

Exponent

1	0	1	1	0	0	0	1	1	1
---	---	---	---	---	---	---	---	---	---

0	0	0	1	1	1
---	---	---	---	---	---

Working

.....

.....

.....

.....

.....

Answer

[3]



(c) The given binary floating-point number is not normalised.

Normalise the floating-point number. Show your working.

Mantissa	Exponent																
<table border="1" style="width: 100%; border-collapse: collapse;"> <tr> <td style="padding: 2px 10px;">0</td><td style="padding: 2px 10px;">0</td><td style="padding: 2px 10px;">0</td><td style="padding: 2px 10px;">0</td><td style="padding: 2px 10px;">0</td><td style="padding: 2px 10px;">0</td><td style="padding: 2px 10px;">0</td><td style="padding: 2px 10px;">1</td><td style="padding: 2px 10px;">1</td><td style="padding: 2px 10px;">1</td> </tr> </table>	0	0	0	0	0	0	0	1	1	1	<table border="1" style="width: 100%; border-collapse: collapse;"> <tr> <td style="padding: 2px 10px;">1</td><td style="padding: 2px 10px;">0</td><td style="padding: 2px 10px;">0</td><td style="padding: 2px 10px;">1</td><td style="padding: 2px 10px;">1</td><td style="padding: 2px 10px;">1</td> </tr> </table>	1	0	0	1	1	1
0	0	0	0	0	0	0	1	1	1								
1	0	0	1	1	1												
Mantissa	Exponent																
<table border="1" style="width: 100%; border-collapse: collapse;"> <tr> <td style="width: 20px; height: 20px;"></td><td style="width: 20px; height: 20px;"></td><td style="width: 20px; height: 20px;"></td><td style="width: 20px; height: 20px;"></td><td style="width: 20px; height: 20px;"></td><td style="width: 20px; height: 20px;"></td><td style="width: 20px; height: 20px;"></td><td style="width: 20px; height: 20px;"></td><td style="width: 20px; height: 20px;"></td><td style="width: 20px; height: 20px;"></td> </tr> </table>											<table border="1" style="width: 100%; border-collapse: collapse;"> <tr> <td style="width: 20px; height: 20px;"></td><td style="width: 20px; height: 20px;"></td><td style="width: 20px; height: 20px;"></td><td style="width: 20px; height: 20px;"></td><td style="width: 20px; height: 20px;"></td><td style="width: 20px; height: 20px;"></td> </tr> </table>						

Working

.....

.....

.....

.....

.....

[3]

(d) The denary number 513 cannot be stored accurately as a normalised floating-point number in this computer system.

(i) Explain the reason for this.

.....

.....

.....

.....

.....

.....

[3]

(ii) Describe an alteration to the way floating-point numbers are stored to enable this number to be stored accurately using the same total number of bits.

.....

.....

.....

.....



2 (a) Describe the purpose of a user-defined data type.

.....
.....
.....
.....
..... [2]

(b) Define, using pseudocode, the following enumerated data types:

(i) SchoolDay to hold data about the days students are usually in school.

.....
..... [1]

(ii) WeekEnd to hold data about the days that are not school days.

.....
..... [1]

(c) Define, using pseudocode, the composite data type ClubMeet. This will hold data about club members that includes:

- first name and last name
- the two days they attend:
 - one on a school day
 - one not on a school day.

Use the enumerated types you created in part (b).

.....
.....
.....
.....
.....
.....
.....
.....
..... [4]



3 (a) Draw **one** line to connect each **Operating System (OS)** term to the **most appropriate** description about it.

OS term	Description
Multi-tasking	Using secondary storage to simulate additional main memory
Paging	Managing the processes running on the CPU
Interrupt handling	Managing the execution of many programs that appear to run at the same time
Scheduling	Locating non-contiguous blocks of data and relocating them
Virtual memory	Transferring control to another routine when a service is required
	Reading/writing same-size blocks of data from/to secondary storage when required

[5]

(b) Explain how an interpreter executes a program without producing a complete translated version of it.

.....

.....

.....

.....

.....

.....

.....

.....

.....

.....

[4]



- 4 (a) (i) Explain why Reverse Polish Notation (RPN) is used to carry out the evaluation of expressions.

.....

 [2]

- (ii) Identify, with reasons, a data structure that could be used to evaluate an expression in RPN.

.....

 [2]

- (b) Write the infix expression in RPN.

$$(a - b) * (a + c) / 7$$

.....
 [1]

- (c) Write the RPN expression as an infix expression.

$$a b / 4 * a b + -$$

.....
 [1]

- (d) Evaluate the RPN expression:

$$a b + c d / /$$

where $a = 17$, $b = 3$, $c = 48$ and $d = 12$.

Show your working.

.....

 [2]

- 5 (a) Calculate the shortest distance between the base and each of the other towns in the diagram using Dijkstra's algorithm.

Show your working **and** write your answers in the table provided.

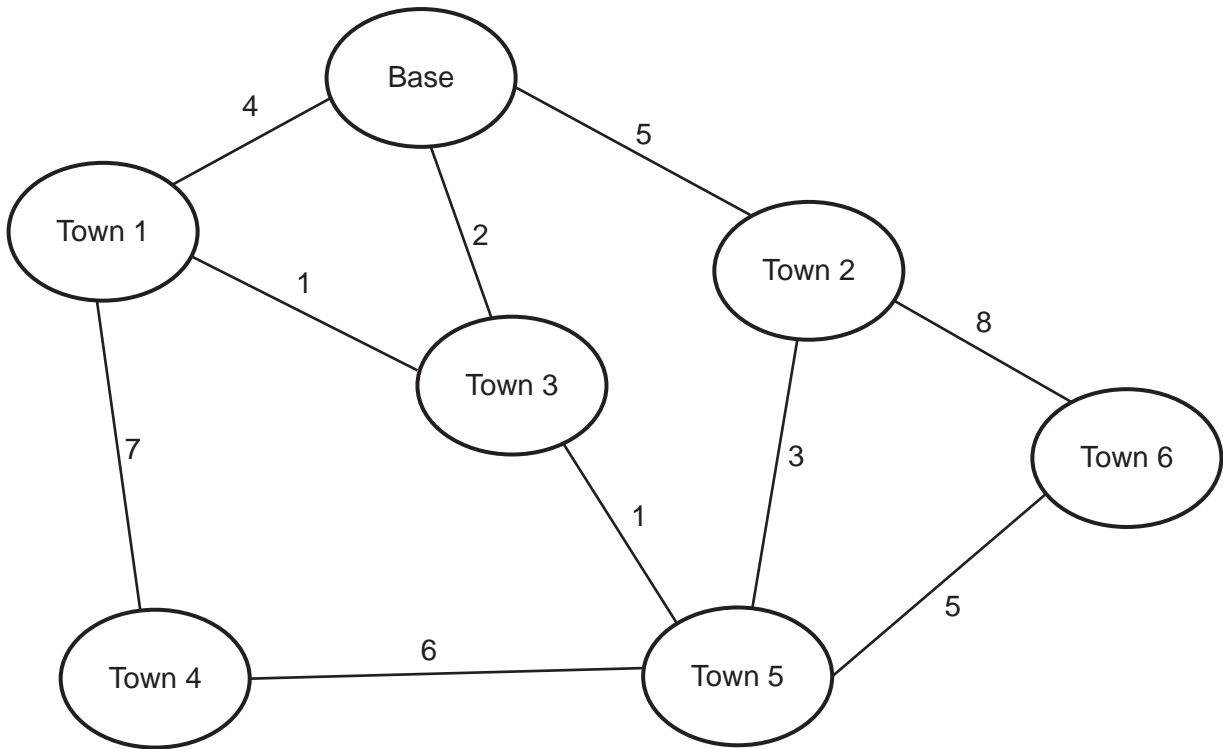

Working

.....

.....

.....

.....

.....

.....

.....

.....

Answers

Town 1	Town 2	Town 3	Town 4	Town 5	Town 6

(b) Explain the use of graphs to aid Artificial Intelligence (AI).

.....

.....

.....

.....

.....

.....

..... [3]

6 Give **two** benefits **and two** drawbacks of packet switching.

Benefit 1

.....

Benefit 2

.....

Drawback 1

.....

Drawback 2

.....

[4]



7 The diagram shows a logic circuit.

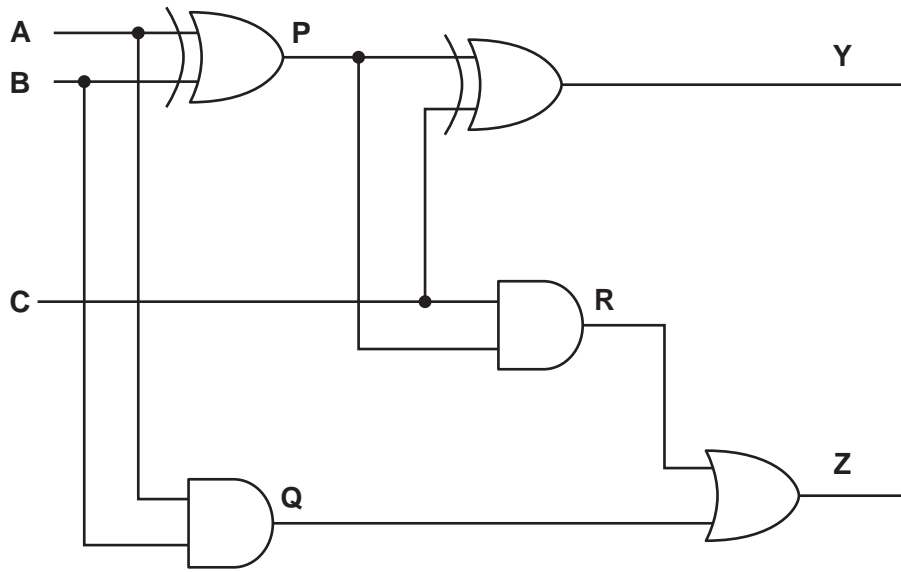

(a) Complete the truth table for the given logic circuit. Show your working.

Inputs			Working space			Outputs	
A	B	C	P	Q	R	Y	Z
0	0	0					
0	0	1					
0	1	0					
0	1	1					
1	0	0					
1	0	1					
1	1	0					
1	1	1					

[3]

(b) State the name of the logic circuit.

..... [1]

(c) Write the Boolean expressions for the two outputs **Y** and **Z** in the truth table as sum-of-products **and** state the purpose of each output.

Y =

Purpose

Z =

Purpose



- 8 (a) State **two** factors that may affect the performance of a sorting algorithm.

.....

.....

.....

..... [2]

- (b) The given algorithm is a simple bubble sort that arranges a set of scores stored in a one-dimensional array into **descending** order, and orders the corresponding students' names stored into a two-dimensional array in the same order as the scores. All the arrays are indexed from 1.

The contents of both arrays after sorting are shown.

	Score
1	98
2	97
...	...
248	5
249	3

	Name	
	1	2
1	Smithfield	Tom
2	Johnson	Jane
...
248	Peters	Jade
249	Allen	John

```

YearSize ← 249
Flag ← TRUE
WHILE Flag = TRUE
  Flag ← FALSE
  FOR Student ← 1 TO YearSize - 1
    IF Score[Student] < Score[Student + 1] THEN
      Temp1 ← Score[Student]
      Temp2 ← Name[Student,1]
      Temp3 ← Name[Student,2]
      Score[Student] ← Score[Student + 1]
      Name[Student,1] ← Name[Student + 1,1]
      Name[Student,2] ← Name[Student + 1,2]
      Score[Student + 1] ← Temp1
      Name[Student + 1,1] ← Temp2
      Name[Student + 1,2] ← Temp3
      Flag ← TRUE
    ENDIF
  NEXT Student
ENDWHILE

```

9 (a) Describe what is meant by **an imperative (procedural)** programming language.

.....

 [2]

(b) Describe what is meant by **a declarative** programming language.

.....

 [2]

(c) Identify the programming paradigm for each of these program code examples.

Program code example	Programming paradigm
<pre>male(john). female(ethel). parent(john, ethel).</pre>	
<pre>FOR Counter = 1 TO 20 X = X * Counter NEXT Counter</pre>	
<pre>Start: LDD Counter INC ACC STO Counter</pre>	
<pre>public class Vehicle { private speed; public Vehicle() { speed = 0; } }</pre>	

[4]

Permission to reproduce items where third-party owned material protected by copyright is included has been sought and cleared where possible. Every reasonable effort has been made by the publisher (UCLES) to trace copyright holders, but if any items requiring clearance have unwittingly been included, the publisher will be pleased to make amends at the earliest possible opportunity.

To avoid the issue of disclosure of answer-related information to candidates, all copyright acknowledgements are reproduced online in the Cambridge Assessment International Education Copyright Acknowledgements Booklet. This is produced for each series of examinations and is freely available to download at www.cambridgeinternational.org after the live examination series.

Cambridge Assessment International Education is part of the Cambridge Assessment Group. Cambridge Assessment is the brand name of the University of Cambridge Local Examinations Syndicate (UCLES), which itself is a department of the University of Cambridge.

