

Please check the examination details below before entering your candidate information

Candidate surname

Other names

Centre Number

Candidate Number

--	--	--	--	--

--	--	--	--	--

Pearson Edexcel International GCSE (9–1)

Time 2 hours

Paper

reference

4CH1/1CR 4SD0/1CR

Chemistry

UNIT: 4CH1

Science (Double Award) 4SD0

PAPER: 1CR

You must have:

Calculator, ruler

Total Marks

Instructions

- Use **black** ink or ball-point pen.
- **Fill in the boxes** at the top of this page with your name, centre number and candidate number.
- Answer **all** questions.
- Answer the questions **in the spaces provided** – *there may be more space than you need.*
- Show all the steps in any calculations and state the units.

Information

- The total mark for this paper is 110.
- The marks for **each** question are shown in brackets – *use this as a guide as to how much time to spend on each question.*

Advice

- Read each question carefully before you start to answer it.
- Write your answers neatly and in good English.
- Try to answer every question.
- Check your answers if you have time at the end.

Turn over ►

P70703A

©2022 Pearson Education Ltd.

L:1/1/1/



Pearson

The Periodic Table of the Elements

1	2	3	4	5	6	7	0																										
7 Li lithium 3	9 Be beryllium 4	11 Na sodium 11	12 C carbon 6	13 Al aluminium 13	14 N nitrogen 7	15 P phosphorus 15	16 O oxygen 8	17 F fluorine 9	18 Ne neon 10																								
19 K potassium 19	20 Ca calcium 20	23 Sc scandium 21	24 Ti titanium 22	25 V vanadium 23	26 Cr chromium 24	27 Mn manganese 25	28 Fe iron 26	29 Co cobalt 27	30 Ni nickel 28	31 Cu copper 29	32 Zn zinc 30	33 Ga gallium 31	34 Ge germanium 32	35 As arsenic 33	36 Se selenium 34	37 Rb rubidium 37	38 Sr strontium 38	39 Y yttrium 39	40 Zr zirconium 40	41 Nb niobium 41	42 Mo molybdenum 42	43 Tc technetium 43	44 Ru ruthenium 44	45 Rh rhodium 45	46 Pd palladium 46	47 Ag silver 47	48 Cd cadmium 48	49 In indium 49	50 Sn tin 50	51 Sb antimony 51	52 Te tellurium 52	53 I iodine 53	54 Xe xenon 54
55 Cs caesium 55	56 Ba barium 56	57 La* lanthanum 57	58 Ce cerium 58	59 Pr praseodymium 59	60 Nd neodymium 60	61 Pm promethium 61	62 Sm samarium 62	63 Eu europium 63	64 Gd gadolinium 64	65 Tb terbium 65	66 Dy dysprosium 66	67 Ho holmium 67	68 Er erbium 68	69 Tm thulium 69	70 Yb ytterbium 70	71 Lu lutetium 71	72 Hf hafnium 72	73 Ta tantalum 73	74 W tungsten 74	75 Re rhenium 75	76 Os osmium 76	77 Ir iridium 77	78 Pt platinum 78	79 Au gold 79	80 Hg mercury 80	81 Tl thallium 81	82 Pb lead 82	83 Bi bismuth 83	84 Po polonium 84	85 At astatine 85	86 Rn radon 86		
[223] Fr francium 87	[226] Ra radium 88	[227] Ac* actinium 89	[261] Rf rutherfordium 104	[262] Db dubnium 105	[266] Sg seaborgium 106	[264] Bh bohrium 107	[277] Hs hassium 108	[268] Mt meitnerium 109	[271] Ds darmstadtium 110	[272] Rg roentgenium 111	Elements with atomic numbers 112–116 have been reported but not fully authenticated																						

1	H hydrogen 1
---	---------------------------

relative atomic mass
atomic symbol
name
atomic (proton) number

* The lanthanoids (atomic numbers 58–71) and the actinoids (atomic numbers 90–103) have been omitted.

The relative atomic masses of copper and chlorine have not been rounded to the nearest whole number.



DO NOT WRITE IN THIS AREA

DO NOT WRITE IN THIS AREA

DO NOT WRITE IN THIS AREA



DO NOT WRITE IN THIS AREA

DO NOT WRITE IN THIS AREA

DO NOT WRITE IN THIS AREA

BLANK PAGE



Turn over

Answer ALL questions.

Some questions must be answered with a cross . If you change your mind about an answer, put a line through the box and then mark your new answer with a cross .

1 This question is about acids, alkalis and indicators.

(a) Which of these is the colour of litmus indicator in an acidic solution?

(1)

- A** blue
- B** orange
- C** red
- D** yellow

(b) Which of these is the pH value of a neutral solution?

(1)

- A** 0
- B** 4
- C** 7
- D** 14

(c) Which of these describes a solution with a pH value of 9?

(1)

- A** strongly acidic
- B** strongly alkaline
- C** weakly acidic
- D** weakly alkaline

DO NOT WRITE IN THIS AREA

DO NOT WRITE IN THIS AREA

DO NOT WRITE IN THIS AREA



(d) Which of these is the chemical formula of an acid?

(1)

- A** HNO_3
- B** H_2O
- C** NaCl
- D** NaOH

(e) Name the type of reaction that occurs when an acid reacts with an alkali.

(1)

(f) Name the two products of the reaction between hydrochloric acid and potassium hydroxide.

(2)

1

2

(Total for Question 1 = 7 marks)



P 7 0 7 0 3 A 0 5 3 6



Turn over

2 (a) (i) State the meaning of the term **solute**.

(1)

.....

.....

(ii) State the meaning of the term **solvent**.

(1)

.....

.....

(b) Explain what is meant by a saturated solution.

(2)

.....

.....

.....

.....

(c) A dark purple liquid is diluted by adding water.

The diluted liquid becomes a pale purple colour.

Explain the process that causes this change.

Refer to particles in your answer.

(2)

.....

.....

.....

.....

.....

(Total for Question 2 = 6 marks)



DO NOT WRITE IN THIS AREA

DO NOT WRITE IN THIS AREA

DO NOT WRITE IN THIS AREA

BLANK PAGE



Turn over

3 This question is about chromatography.

Two students carry out separate chromatography experiments to find the R_f values for five different food dyes, A, B, C, D and E.

- (a) State two things that should be the same in both experiments so that the students can compare their results fairly.

(2)

1

2

- (b) After doing the experiments the students calculate the R_f value for each food dye.

The table shows their results.

Dye	Student 1 R_f value	Student 2 R_f value
A	0.45	0.45
B	0.63	0.64
C	0.00	0.00
D	0.83	1.20
E	0.30	0.30

- (i) State what can be concluded about dye C.

(1)

.....

- (ii) Explain which R_f value cannot be correct.

(2)

.....

.....

.....

.....



(c) The diagram shows a chromatogram for a different food dye.

Some distances are shown on the diagram.

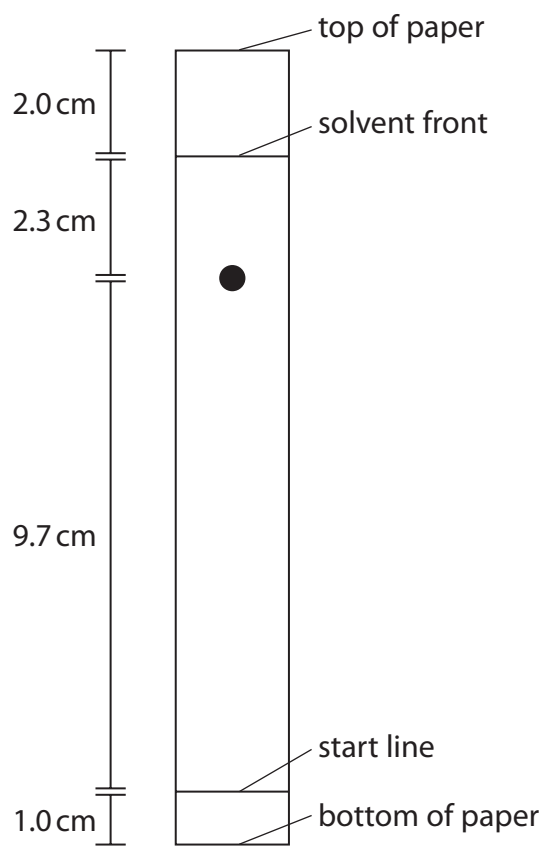

Calculate the R_f value for this food dye.

Give your answer to two significant figures.

(3)

$R_f =$

(Total for Question 3 = 8 marks)



Turn over

4 (a) State the meaning of the term **atomic number**.

(1)

.....

.....

(b) An atom of element X contains 14 protons, 14 electrons and 15 neutrons.

(i) Which of these is the mass number of this atom?

(1)

A 14

B 15

C 28

D 29

(ii) Explain which group of the Periodic Table element X belongs to.

(2)

.....

.....

.....

.....

DO NOT WRITE IN THIS AREA

DO NOT WRITE IN THIS AREA

DO NOT WRITE IN THIS AREA



- (c) The table shows the composition of a sample of a different element, Y, containing three isotopes.

Mass number of isotope	Percentage of isotope in sample
32	95.0
33	0.75
34	4.25

Using information from the table, calculate the relative atomic mass (A_r) of this sample of element Y.

Give your answer to one decimal place.

(3)

$A_r =$

(Total for Question 4 = 7 marks)



P 7 0 7 0 3 A 0 1 1 3 6



Turn over

5 This is a question about metals and their compounds.

(a) State one property of metals.

(1)

(b) Mercury is the only metal that is liquid at room temperature.

Describe the difference in the movement of particles in liquid mercury and in a solid metal.

(2)

(c) Magnesium is a metal that burns in air.

(i) State one observation made during the combustion of magnesium metal.

(1)

(ii) State one chemical property of the product of combustion that can be used to classify magnesium as a metal.

(1)

(d) In the absence of air, magnesium reacts with sulfur to form the ionic compound magnesium sulfide, MgS

(i) Give a reason why the reaction needs to be done in the absence of air.

(1)



(ii) Describe, in terms of electrons, the formation of the ions in magnesium sulfide.

Give the charges on the ions.

(3)

(iii) Explain why magnesium sulfide has a very high melting point.

(3)

(iv) Magnesium sulfide reacts with hydrochloric acid to form magnesium chloride and hydrogen sulfide gas, H_2S

Give the chemical equation for this reaction.

(2)

(Total for Question 5 = 14 marks)

DO NOT WRITE IN THIS AREA

DO NOT WRITE IN THIS AREA

DO NOT WRITE IN THIS AREA



P 7 0 7 0 3 A 0 1 3 3 6



Turn over

6 Ocimene is an organic compound that gives some plants their particular smell.

The molecular formula of ocimene is $C_{10}H_{16}$

(a) Calculate the relative formula mass (M_r) of ocimene.

(1)

$M_r =$

(b) Using ocimene as an example, explain what is meant by the term **empirical formula**.

(2)

.....

.....

.....

.....

(c) The displayed formula of ocimene is

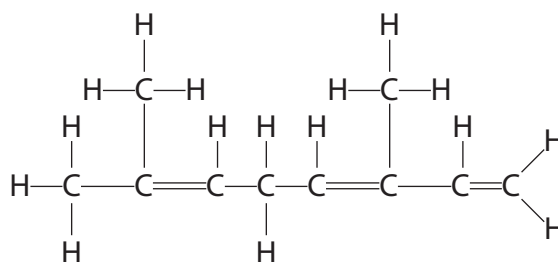

Explain why ocimene is described as an unsaturated hydrocarbon.

(3)

.....

.....

.....

.....

.....

.....



(d) Ocimene is an alkene.

(i) Which of these types of reaction occurs between ocimene and bromine?

(1)

- A addition
- B polymerisation
- C precipitation
- D substitution

(ii) Many alkenes have the general formula C_nH_{2n}

Suggest why ocimene does not have this general formula.

(1)

.....

.....

.....

(e) Ocimene can take part in combustion reactions.

Complete the equation for the complete combustion of ocimene.

(2)

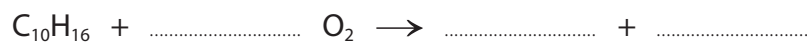

(f) Two different products can form during the incomplete combustion of ocimene. One product is a solid and the other is a poisonous gas.

(i) Identify these two products.

(2)

.....

.....

(ii) State why the gas produced is poisonous.

(1)

.....

.....

.....

.....

(Total for Question 6 = 13 marks)



DO NOT WRITE IN THIS AREA

DO NOT WRITE IN THIS AREA

DO NOT WRITE IN THIS AREA

7 (a) Explain the meaning of the term **thermal decomposition**.

(2)

.....

.....

.....

.....

(b) The equation for the thermal decomposition of potassium hydrogencarbonate is



Calculate the maximum mass of K_2CO_3 that could be produced from the thermal decomposition of 2.50 g of KHCO_3

(4)

maximum mass of K_2CO_3 = g

(Total for Question 7 = 6 marks)



P 7 0 7 0 3 A 0 1 7 3 6



Turn over

DO NOT WRITE IN THIS AREA

DO NOT WRITE IN THIS AREA

DO NOT WRITE IN THIS AREA

BLANK PAGE



- 8 A student uses this apparatus in an experiment to study the rate of the reaction between zinc and dilute sulfuric acid.

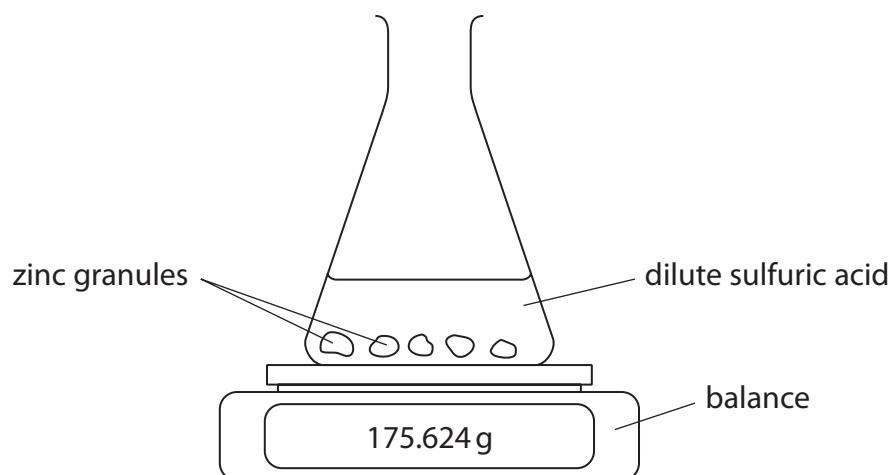

This is the student's method.

- add a few zinc granules to a conical flask on a balance
- add 100 cm^3 of dilute sulfuric acid to the flask, start a timer and immediately record the mass of the flask and contents
- record the mass of the flask and contents every minute until the mass remains constant

The mass of the flask and contents decreases because hydrogen gas is produced and leaves the flask.

The student uses the mass readings to calculate the total mass of hydrogen produced.

- (a) Complete the equation for the reaction by adding the state symbols.

(1)

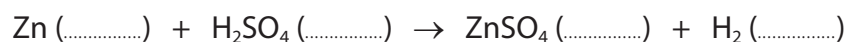

(b) The table shows the student's results.

Time in minutes	Total mass of hydrogen produced in mg
0	0
1	80
2	110
3	130
4	148
5	162
6	165
7	184
8	192
9	198
10	204
11	209
12	214
13	218
14	220
15	220

(i) Plot the student's results. The first three have been done for you.

(1)

(ii) Draw a circle around the anomalous result.

(1)

(iii) Draw a curve of best fit.

(1)



DO NOT WRITE IN THIS AREA

DO NOT WRITE IN THIS AREA

DO NOT WRITE IN THIS AREA

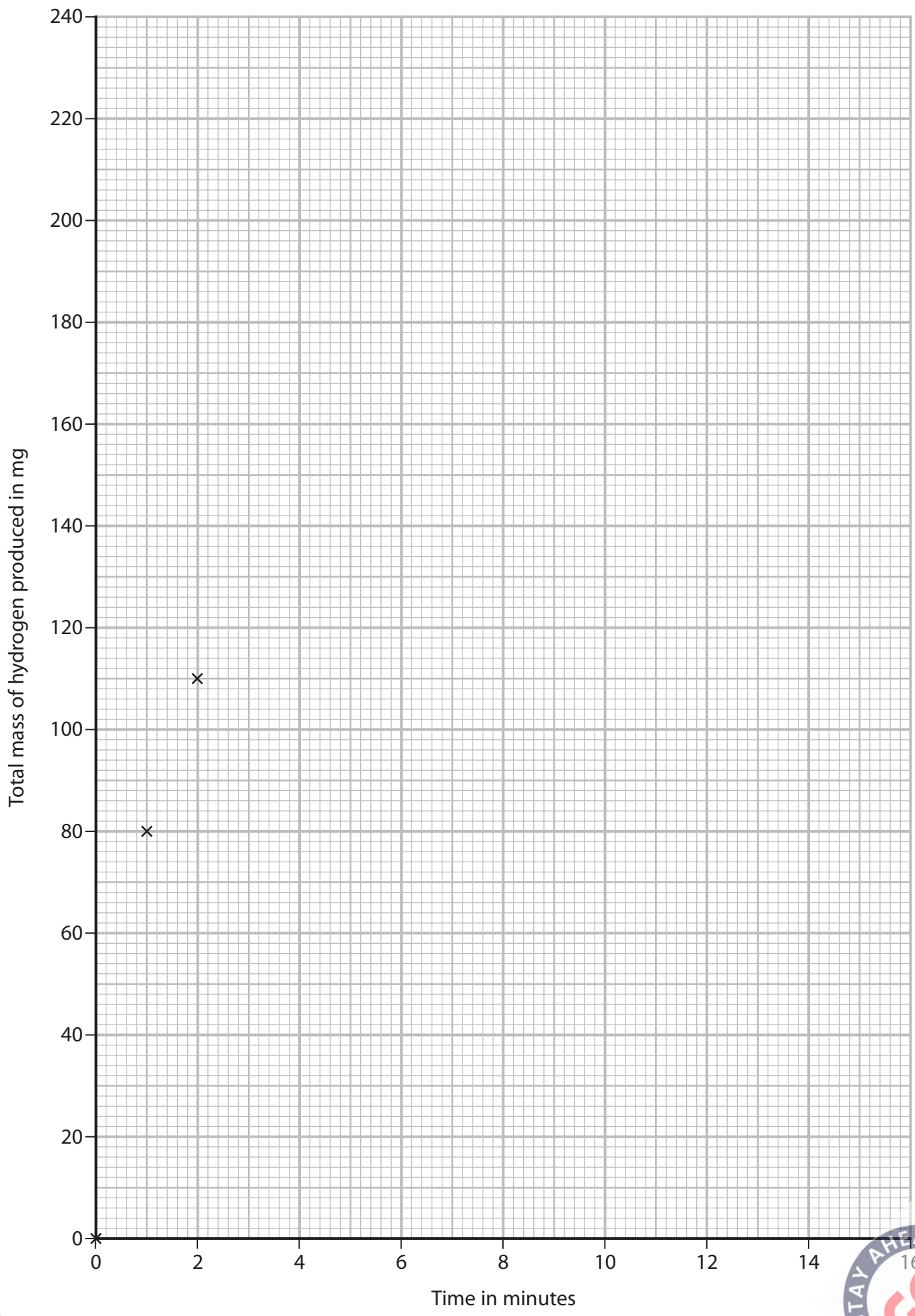

Turn over



(iv) Give a possible reason for the anomalous result.

(1)

(v) Determine a more likely value for this result.

(1)

(c) (i) Explain how the shape of the curve shows how the rate of the reaction changes as time increases.

(2)

(ii) At the end of the experiment there is no zinc left in the flask.

Give a conclusion the student could make from this observation.

(1)

DO NOT WRITE IN THIS AREA

DO NOT WRITE IN THIS AREA

DO NOT WRITE IN THIS AREA



(d) The student does another experiment using

- the same amount of similarly sized magnesium granules instead of zinc
- the same volume of sulfuric acid, but of a lower concentration

Explain why it is difficult to predict how the rate of reaction in this experiment compares with the rate of reaction in the first experiment.

(3)

.....

.....

.....

.....

.....

.....

.....

.....

.....

.....

(e) Explain, in terms of particle collision theory, how increasing the temperature affects the rate of a reaction.

(3)

.....

.....

.....

.....

.....

.....

.....

.....

.....

.....

(Total for Question 8 = 15 marks)



P 7 0 7 0 3 A 0 2 3 3 6



Turn over

- 9 A student is given a mixture of two white solid compounds, and a colourless solution containing the same two compounds.

The student is told that one of the compounds is a halide and that the other compound is a carbonate.

- (a) Give two reasons why the student should know, without doing any tests, that one of the compounds **cannot** be copper(II) carbonate.

(2)

1

2

- (b) Describe tests the student could do to show that the mixture contains potassium carbonate and potassium iodide.

(6)

(Total for Question 9 = 8 marks)



DO NOT WRITE IN THIS AREA

DO NOT WRITE IN THIS AREA

DO NOT WRITE IN THIS AREA

BLANK PAGE



P 7 0 7 0 3 A 0 2 5 3 6



Turn over

10 (a) A student is given a pure sample of sodium carbonate crystals and is told that the formula of the crystals is $\text{Na}_2\text{CO}_3 \cdot x\text{H}_2\text{O}$

State what $x\text{H}_2\text{O}$ in the formula shows about the sodium carbonate crystals.

(1)

(b) The student uses this apparatus to find the value of x in $\text{Na}_2\text{CO}_3 \cdot x\text{H}_2\text{O}$

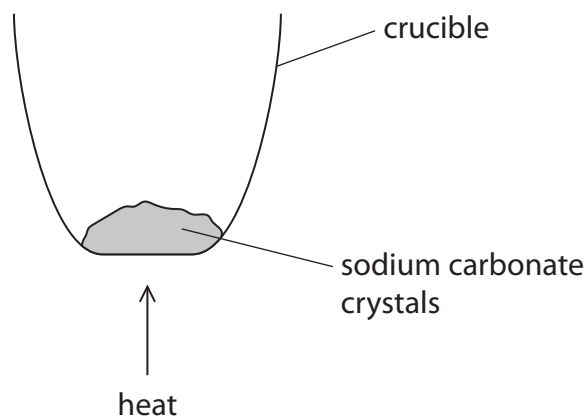

This is the student's method.

- find the mass of an empty crucible without a lid
- add some sodium carbonate crystals $\text{Na}_2\text{CO}_3 \cdot x\text{H}_2\text{O}$ to the crucible
- find the total mass of the crucible and sodium carbonate crystals
- heat the crucible to remove water from the crystals
- allow the crucible and contents to cool down
- find the mass of the cold crucible and contents

These are the student's results.

	Mass in grams
empty crucible	22.75
crucible and sodium carbonate crystals $\text{Na}_2\text{CO}_3 \cdot x\text{H}_2\text{O}$	29.71
cold crucible and contents	25.93



(i) Calculate the mass of sodium carbonate left after heating and cooling. (1)

mass of sodium carbonate = g

(ii) Calculate the mass of H₂O lost from the sodium carbonate crystals during heating. (1)

mass of H₂O = g

(iii) Show that the student's results suggest that the formula of the sodium carbonate crystals is Na₂CO₃·7H₂O
[M_r of Na₂CO₃ = 106 M_r of H₂O = 18] (3)

DO NOT WRITE IN THIS AREA

DO NOT WRITE IN THIS AREA

DO NOT WRITE IN THIS AREA



Turn over



(c) The student's teacher says that the correct formula of the sodium carbonate crystals is $\text{Na}_2\text{CO}_3 \cdot 10\text{H}_2\text{O}$

(i) The student did not make any mistakes in their measurements.

Explain what could have caused the student's value for x to be too low.

(2)

(ii) Describe how the student could improve the method to obtain a more accurate value for x .

(2)

(Total for Question 10 = 10 marks)



DO NOT WRITE IN THIS AREA

DO NOT WRITE IN THIS AREA

DO NOT WRITE IN THIS AREA

BLANK PAGE



P 7 0 7 0 3 A 0 2 9 3 6



Turn over

11 A student investigates the temperature change during the reaction between zinc metal and copper(II) sulfate solution.

The student considers two different methods.

Method 1

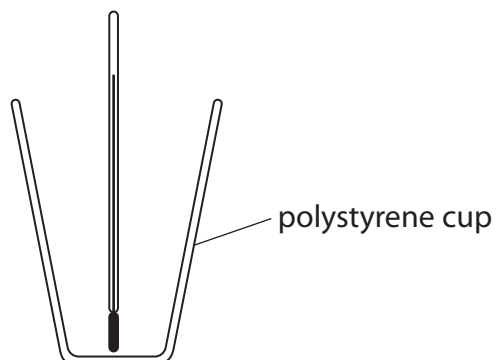

- pour 50 cm³ of copper(II) sulfate solution into the polystyrene cup
- record the temperature of the solution
- add 3 g of zinc powder
- stir using the thermometer and record the highest temperature reached

Method 2

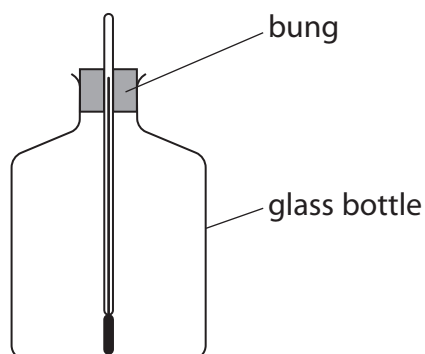

- record the temperature of 50 cm³ of copper(II) sulfate solution
- pour the 50 cm³ of copper(II) sulfate solution into the glass bottle
- add 3 g of zinc powder
- push the bung and thermometer into the bottle and record the highest temperature reached

DO NOT WRITE IN THIS AREA

DO NOT WRITE IN THIS AREA

DO NOT WRITE IN THIS AREA



(a) Discuss the advantages and disadvantages of each method.

(6)

DO NOT WRITE IN THIS AREA

DO NOT WRITE IN THIS AREA

DO NOT WRITE IN THIS AREA

Area with horizontal dotted lines for writing.



Turn over

(b) The equation for the reaction is

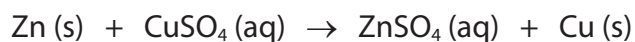

50 cm³ of copper(II) sulfate solution contains 0.025 mol CuSO₄

A mass of 3 g of zinc is used.

Show that the zinc is in excess.

[A_r of zinc = 65]

(2)

(c) The student reacts a solution containing 0.025 mol CuSO₄ with an excess of zinc.

These are the student's results.

temperature of 50 cm³ of copper(II) sulfate solution = 21.1 °C

highest temperature reached = 40.6 °C

(i) Show that the energy change Q for this reaction is about 4000 J

[mass of 1 cm³ of solution = 1.0 g]

[for the solution, c = 4.2 J/g/°C]

(3)



(ii) Calculate the molar enthalpy change (ΔH), in kJ/mol, for the reaction.

(3)

$\Delta H = \dots\dots\dots$ kJ/mol

(d) The ionic equation for the reaction is

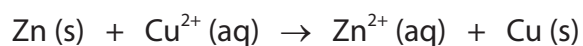

Explain what is oxidised and what is reduced in this reaction.

(2)

.....

.....

.....

.....

.....

.....

.....

(Total for Question 11 = 16 marks)

TOTAL FOR PAPER = 110 MARKS

DO NOT WRITE IN THIS AREA

DO NOT WRITE IN THIS AREA

DO NOT WRITE IN THIS AREA



P 7 0 7 0 3 A 0 3 3 3 6



DO NOT WRITE IN THIS AREA

DO NOT WRITE IN THIS AREA

DO NOT WRITE IN THIS AREA

BLANK PAGE



DO NOT WRITE IN THIS AREA

DO NOT WRITE IN THIS AREA

DO NOT WRITE IN THIS AREA

BLANK PAGE



DO NOT WRITE IN THIS AREA

DO NOT WRITE IN THIS AREA

DO NOT WRITE IN THIS AREA

BLANK PAGE

